

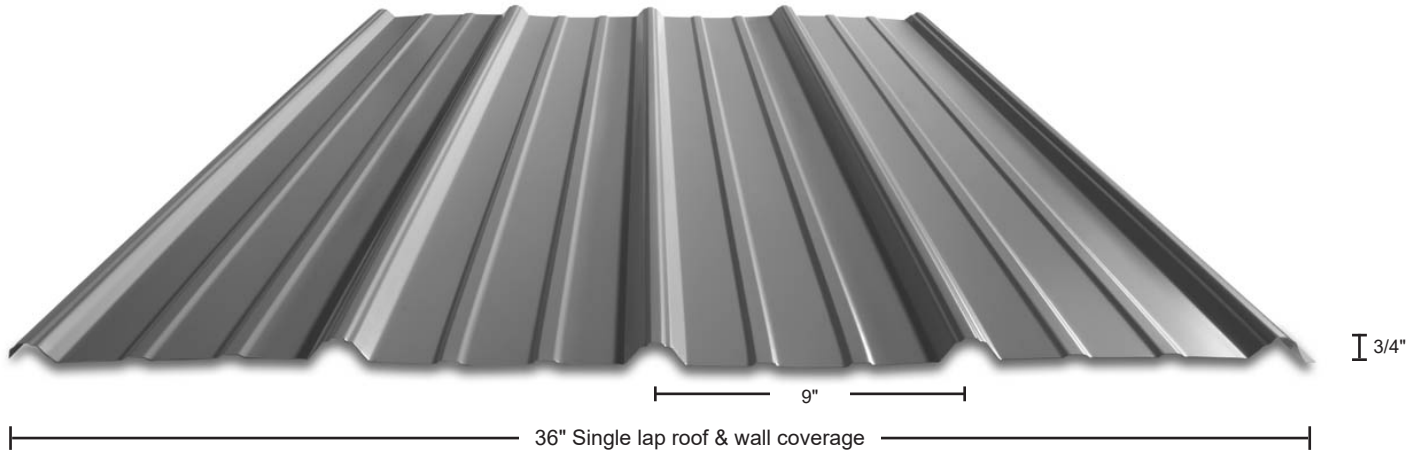

**CHAMPION METAL**  
a Taylor Metal Company

# Ultra-Panel™



Ultra-Panel's positive side lap keeps panels square and acts as an excellent anti-siphon that prevents leakage at the seams - eliminating the need for side lap tape and stitch screws. Because the side lap is virtually invisible, the Ultra-Panel has a clean, attractive appearance.

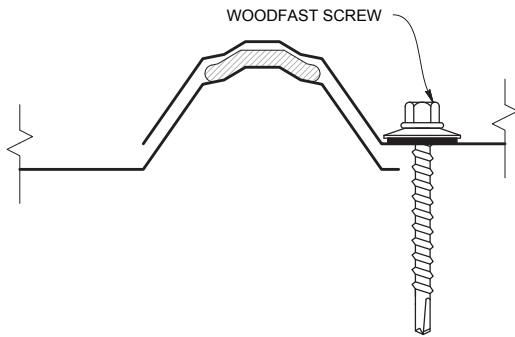

## KEY FEATURES

- 29 gauge
- ASTM 653 and 792
- 36" roof and wall coverage
- Polycarbonate skylight panels available to match profile
- Panel is available in a wide variety of "Cool" baked on ARMORTECH™ colors
- Easy-to-order standard and custom made trim and accessory packages available for specific project needs
- Color matched neoprene washered screws available
- Custom Cuts 3' to 33'

29 GAUGE	24"	30"	36"	48"	60"
Live Load	158	101	70	36	19
Wind Load	205	131	91	47	25

### Notes:

1. Continuous over three spans
2. Structural design analysis per AISI Specification of the Design of Cold-Formed Steel Structural Members, 1968
3. For wind loads, a 1/3 increase in loads is allowed

## MATERIAL SPECIFICATIONS

- 29 gauge ARMORTECH™ Painted Steel .015" (Thickness prior to painting) G-90 Galvanized or AZ-55 Zincalume®
- 29 gauge bare Zincalume® Plus, AZ-55 (No finish warranty – 25 yr. perforation warranty)
- 29 gauge bare G-90 Galvanized (No finish warranty – no perforation warranty)

## KEY FEATURES

- 20 Standard Colors, Zincalume® Plus and Galvanized
- ArmorTech™ Paint System - excellent in exterior durability
- “Cool” color pigments are specially designed to reflect infrared light, reducing heat gain to dwelling, and conform with ENERGY STAR® criteria
- Superior Quality, two coat SMP resin system at 1 mil. thickness

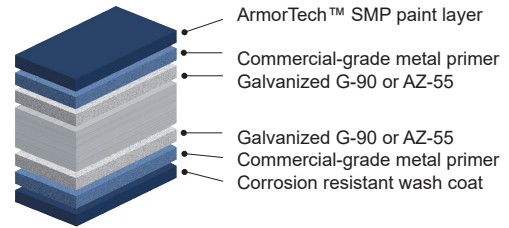

### 40-Year Residential Manufacturer's Limited Warranty

## STANDARD COOL ARMORTECH™ SMP COLORS

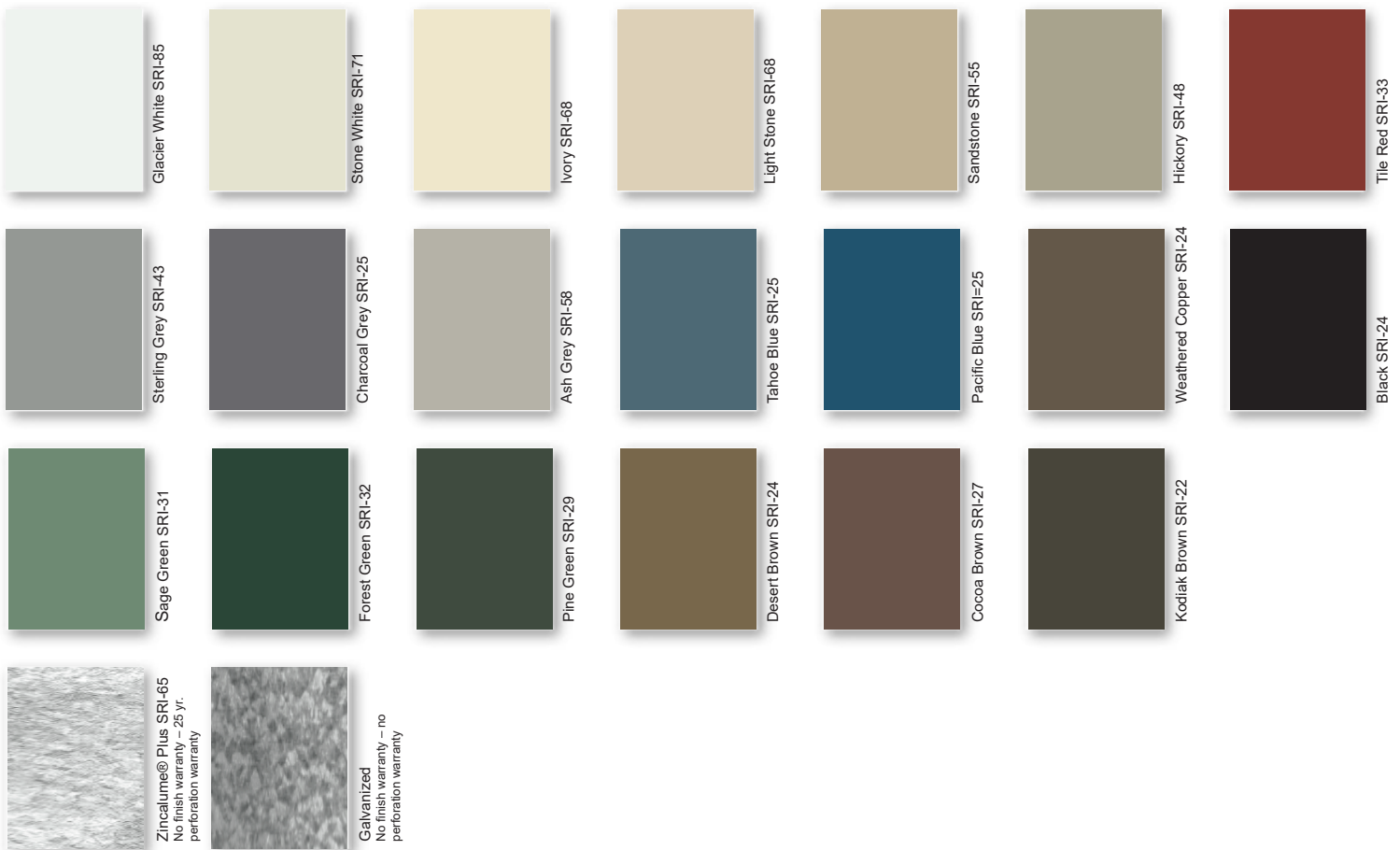

These printed chips provide a close representation of the colors.

Metal samples are available upon request.

SRI = Solar Reflective Index. SRI values listed above are in accordance with ASTM E 1980 and are based on actual testing.

“Oil canning” is an inherent characteristic of Roof & Wall products, not a defect, and is not a cause for panel rejection.