



CHAMPION METAL

a Taylor Metal Company



MS-100™
MS-150™ Flashing and Details Guide



CHAMPION METAL
a Taylor Metal Company

MS-100™

MECHANICALLY SEAMED



The MS-100™ is a mechanically seamed roof that is perfect for high wind areas and snow country. The butyl injected seam prevents water from entering the system, giving you a worry free roof for a lifetime.

KEY FEATURES

- 12" to 21" coverage options
- 26, 24 & 22 gauge Tru-Gauge™, .032 Aluminum and 24 gauge Bonderized (G-90)
- 16 & 20 oz. Copper
- Floating clip system: allows for expansion/contraction of panels in longer lengths
- 1" vertical rib
- Factory injected Butyl sealant
- Concealed fasteners: fasteners cannot leak
-  - Code compliance UL Evaluation Report UL ER 25913-01
- UL580 Class 90: Dade impact: Dade 90
Dade 140 MPH: UL Class 4 hail
- ASTM E-2140: ASTM-1646: ASTM 1680:
ASTM 283: ASTM 330: ASTM 331:
ASTM E-1592
- UL Class A fire rated
- UL Construction No. 554
- 1:12 minimum pitch recommended:
For lower panels, please inquire
- Standard panel lengths 2' to 65':
For longer panels, please inquire
- Onsite roll forming available
- Pan options: Flat pan, Accent ribs, Striations
- Retro-fit systems available



FLAT PAN
12" to 21" coverage options

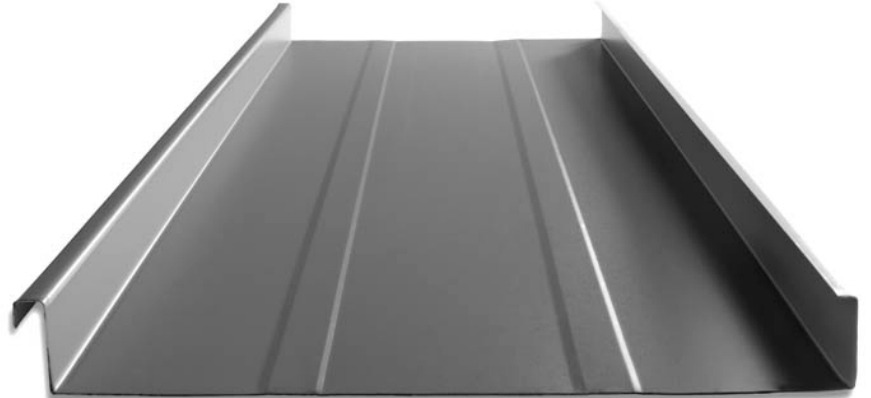

ACCENT RIBS

2 Accent ribs for 12" to 14 1/4" panel
3 Accent ribs for 16" & 21" panel



STRIATED

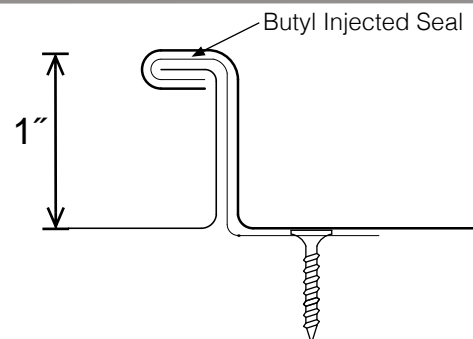

MATERIAL SPECIFICATIONS

- 26 gauge Kynar 500® Painted Steel .019" (thickness prior to painting) G-90 Galvanized or AZ-50
- 24 gauge Kynar 500® Painted Steel .0236" (thickness prior to painting) G-90 Galvanized or AZ-50
- 26, 24 & 22 gauge bare Zincolume® Plus with Clear Acrylic Coating-AZ-55
- ▲ 22 gauge Kynar 500® Painted Steel .029" (thickness prior to painting) G-90 Galvanized or AZ-50
- ◆ .032 Kynar 500® Painted Aluminum
- 24 gauge Bonderized (G-90)
- 16 and 20 ounce Copper *please inquire*
- Kynar and substrate testing data available (See website)

KEY FEATURES

- 21 Standard Colors, 5 Metallic Colors and 5 Specialized Colors
- Kynar 500® Paint System-the ultimate in exterior durability and color retention
- "Cool" color pigments are specially designed to reflect infrared light, reducing heat gain to dwelling, and conform with ENERGY STAR® criteria
- Superior quality, two-coat, 70% resin finish, applied at a 1 mil. thickness
- 40-year residential paint warranty
- 20 and 30 year commercial paint warranty: (Contact **Champion Metal** for warranty specifications)

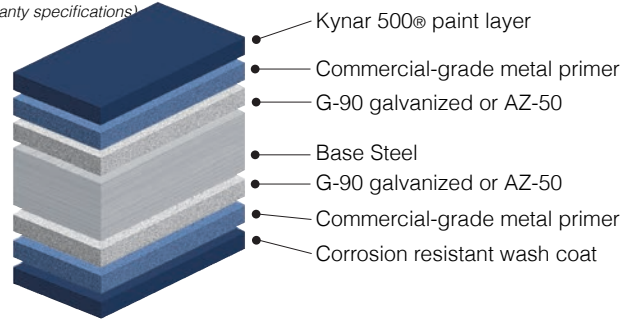

40-Year Residential/ 20 and 30 Year Commercial Manufacturer's Limited Warranty

STANDARD 24g COOL KYNAR 500® COLORS

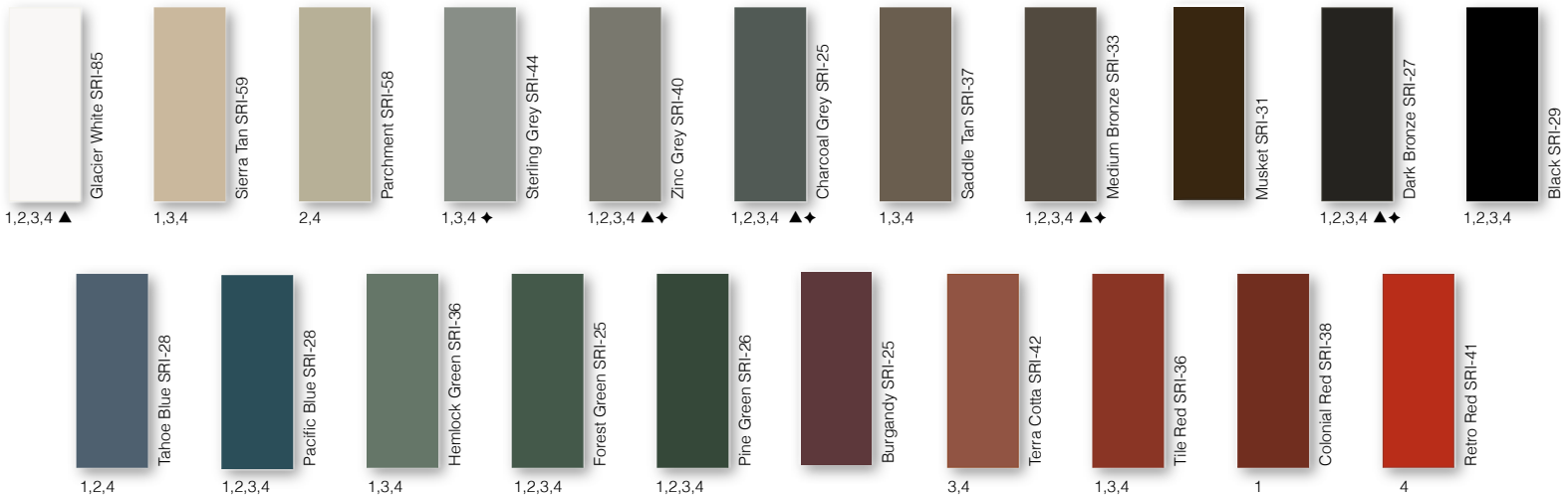

METALLIC COOL KYNAR 500® COLORS

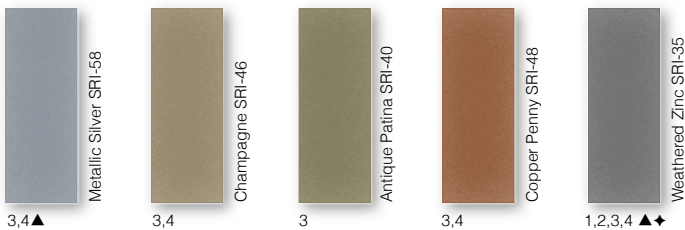

SPECIALIZED MATERIAL

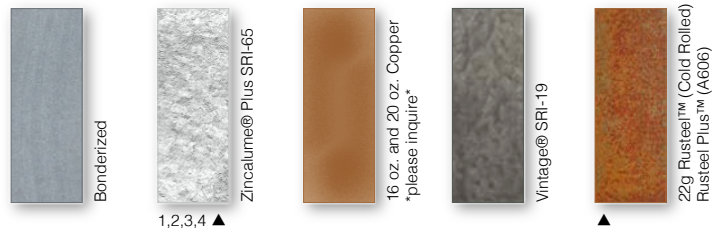

These printed chips provide a close representation of the colors.

Metal samples are available upon request.

Coatings are low gloss 10-15% sheen

"Oil canning" is an inherent characteristic of Roof & Wall products, not a defect, and is not a cause for panel rejection. SRI = Solar Reflective Index. SRI values listed above are in accordance with ASTM E 1980 and are based on actual testing.

Standard MS100 Panels				
Width	Gauge	Color	LBS SQFT	LBS LF
14"	26	1	.98	1.14
14"	24	2	1.15	1.34
17½"	24	3	1.11	1.65
21¼"	24	4	1.09	1.93
13¼"	22	▲	1.46	1.61
21¼"	22	▲	1.37	2.42
17½"	.032	◆	.52	.81



CHAMPION METAL
a Taylor Metal Company

MS-150™ MECHANICALLY SEAMED



The MS-150™ is a mechanically seamed roof that is perfect for high wind areas and snow country. The butyl injected seam prevents water from entering the system, giving you a worry free roof for a lifetime.

- 12" to 21" coverage options
- 26, 24 & 22 gauge Tru-Gauge™, .032 Aluminum and 24 gauge Bonderized (G-90)
- 16 & 20 oz. Copper *please inquire*
- Floating clip system: allows for expansion/contraction of panels in longer lengths
- 1½" vertical rib
- Factory injected Butyl sealant
- Concealed fasteners: fasteners cannot leak
- Code compliance UL Evaluation Report UL EB-25913-01
- UL580 Class 90: Dade impact: Dade 90 Dade 140 MPH: UL Class 4 hail
- ASTM E-2140: ASTM-1646: ASTM 1680: ASTM 283: ASTM 330: ASTM 331: ASTM E-1592
- UL Class A fire rated
- UL Construction No. 554
- Weather tightness warranties available- 5 to 30 Year Prorated or NDL
(Contact *Champion Metal* representative for details)
- 1:12 minimum pitch recommended: for lower pitches please inquire
- Standard panel lengths 2' to 65': for longer panels, please inquire
- Onsite roll forming available
- Pan options: Flat pan, Accent ribs, Striations
- Retro-fit systems available

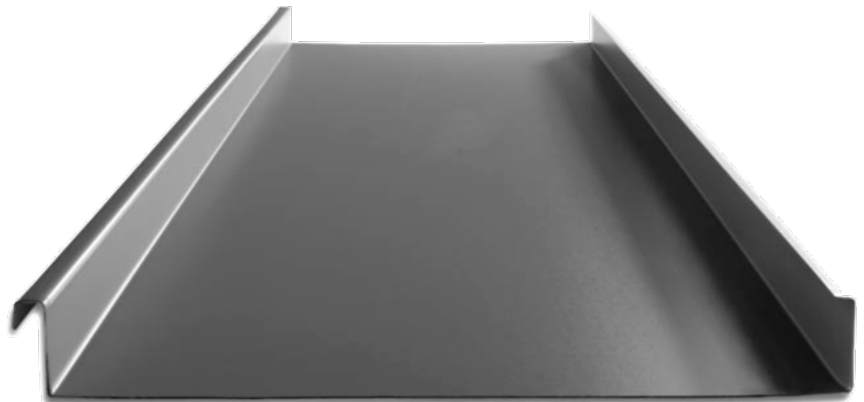

FLAT PAN
12" to 21" coverage options



ACCENT RIBS

2 Accent ribs for 12" to 14¾ panel
3 Accent ribs for 16" & 21" panel



STRIATED

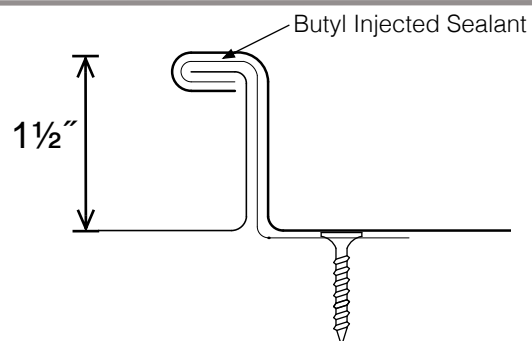

MATERIAL SPECIFICATIONS

- 26 gauge Kynar 500® Painted Steel .019" (thickness prior to painting) G-90 Galvanized or AZ-50
- 24 gauge Kynar 500® Painted Steel .0236" (thickness prior to painting) G-90 Galvanized or AZ-50
- 26, 24 & 22 gauge bare Zincolume® Plus with Clear Acrylic Coating-AZ-55
- ▲ 22 gauge Kynar 500® Painted Steel .029" (thickness prior to painting) G-90 Galvanized or AZ-50
- ◆ .032 Kynar 500® Painted Aluminum
- 24 gauge Bonderized (G-90)
- 16 and 20 ounce Copper *please inquire*
- Kynar and substrate testing data available (See website)

KEY FEATURES

- 21 Standard Colors, 5 Metallic Colors and 5 Specialized Colors
- Kynar 500® Paint System-the ultimate in exterior durability and color retention
- "Cool" color pigments are specially designed to reflect infrared light, reducing heat gain to dwelling, and conform with ENERGY STAR® criteria
- Superior quality, two-coat, 70% resin finish, applied at a 1 mil. thickness
- 40-year residential paint warranty
- 20 and 30 year commercial paint warranty: (Contact **Champion Metal** for warranty specifications)

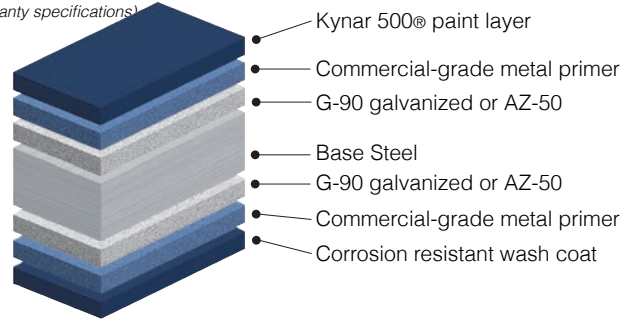

40-Year Residential/ 20 and 30 Year Commercial Manufacturer's Limited Warranty

STANDARD 24g COOL KYNAR 500® COLORS

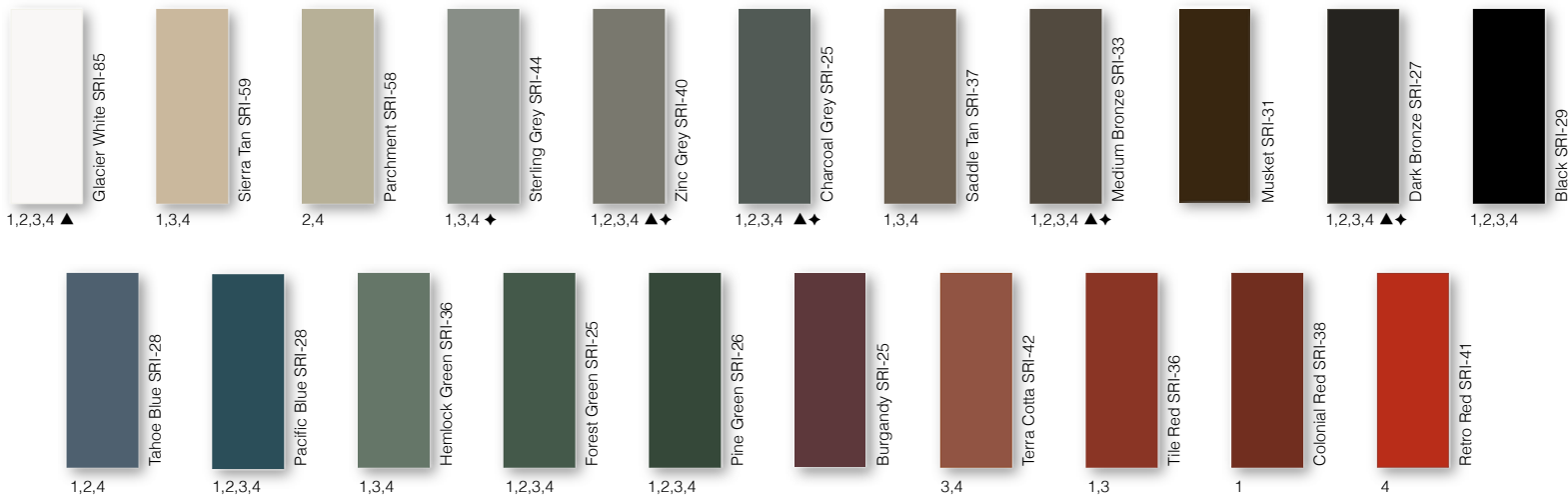

METALLIC COOL KYNAR 500® COLORS

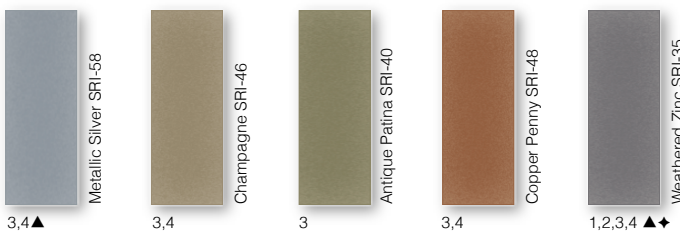

SPECIALIZED MATERIAL

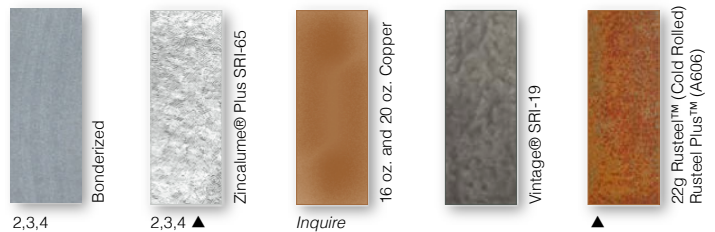

These printed chips provide a close representation of the colors.

Metal samples are available upon request.

Coatings are low gloss 10-15% sheen

"Oil canning" is an inherent characteristic of Roof & Wall products, not a defect, and is not a cause for panel rejection. SRI = Solar Reflective Index. SRI values listed above are in accordance with ASTM E 980 and are based on actual testing.

Standard MS150 Panels				
Width	Gauge	Color	LBS SQFT	LBS LF
12¾"	26	1	1.05	1.14
12¾"	24	2	1.24	1.34
16½"	24	3	1.18	1.65
20"	24	4	1.14	1.93
12"	22	▲	1.58	1.61
20"	22	▲	1.43	2.42
16½"	.032	◆	.55	.81



NOTES TO DESIGNER/INSTALLER..... pg. 4-5

HANDLING/STORAGE & SAFETY..... pg. 6

HOOK EAVE DETAIL..... pg. 7

HOOK EAVE WITH GUTTER DETAIL..... pg. 8

STANDARD RIDGE DETAIL..... pg. 9

VENTED RIDGE DETAIL..... pg. 10

STANDARD VALLEY DETAIL..... pg. 11

ALTERNATE VALLEY DETAIL..... pg. 12

STANDARD GABLE DETAIL..... pg. 13

ALTERNATE GABLE DETAIL..... pg. 14

SIDE WALL DETAIL..... pg. 15

RIDGE END CAP DETAIL pg. 16

VENTED RIDGE END CAP DETAIL..... pg. 17

PITCH CHANGE DETAIL..... pg. 18

END WALL DETAIL..... pg. 19

VENTED END WALL DETAIL pg. 20

BACK PAN/CRICKET ISO DETAIL pg. 21

CURB SIDE WALL DETAIL..... pg. 22

CURB HEAD DETAIL..... pg. 23

CURB BACK PAN..... pg. 24

PIPE PENATRATION DETAIL 1..... pg. 25

PIPE PENATRATION DETAIL 2..... pg. 26

PIPE PENETRATION MID PANEL..... pg. 27

ROOF END DAM ASSEMBLY..... pg. 28

FLASHING SELECTION..... pg. 29-31



Ventilation/Insulation

It is the responsibility of the designer to determine the material types needed to control condensation and to insulate and ventilate the roof system. Applications over rigid insulation may require blocking for solid attachment and framing the perimeter for installation of perimeter flashings.

Oil Canning

Flat metal surfaces will display waviness commonly referred to as "oil canning." Oil canning is caused by a variety of conditions: Steel mill tolerances, variations in or uneven substrates and roofing underlayments. Oil canning is a characteristic of metal roofing, not a defect and is not a cause for rejection. Champion Metal offers MS150™ with striations or accent ribs to help minimize oil canning.

Thermal Movement

The Panels and the flashings must be allowed to expand and contract, especially with longer length panels. The panel may need to have a slight gap where the panel hooks the offset cleat to allow for thermal movement of the panels.

Snow Design

The following details do not address all conditions for snow environments. Consult with the designers, engineers, and others for acceptable details to accommodate your project and climate conditions. When possible, gutters, valleys, pitch changes or other penetrations should be minimized in snow areas.

All roof penetrations should be located as close to the ridge or top of roof. Snow country requires special designs for valleys to accommodate accumulation of snow and ice from uphill panels. Roof design should be considered in snow areas. Roof design should help resist the melting and freezing of snow and ice. A fit for purpose roof design has the greatest impact on maintaining a damage free roof system in snow areas. Please contact a Champion Metal representative for assistance in detail designs and appropriate panel selection for specific climate and building conditions.



Handling / Storage & Safety

Handle materials with care when off-loading or moving materials to avoid damage to panels or flashings. Long panels may require two or more pick-up points, properly spaced to avoid damaging panels. Plan ahead; contact Champion Metal for recommendations on handling/hoisting long panels.

Store the panels, flashings and accessories in a dry, well ventilated area, off the ground. If covering, allow ventilation around panels. Elevate one end of bundle to allow drainage of wet materials.

Wear clean, soft-soled shoes when walking on roofing panels to avoid damage to the painted finish.

Take care that sand, gravel, dirt, etc. sticking to your shoes is not carried onto the roof, scratching or otherwise damaging the finish on the roofing material. Walking on asphalt impregnated felt paper, especially on a hot day, can cause the asphalt to stick to your shoes and be tracked on to the roofing material.

Take care when painting to avoid getting over spray on the roofing material. Remember that wind can carry paint particles some distance. Over spray can cause the finish of the roofing material to look dull and may void your warranty.

Secure materials, especially when leaving the site, on the ground or roof to prevent winds from moving the materials. Wind-blown materials may cause damage to the material, property or persons.

Always use proper safety equipment and attire to minimize risk of cuts or other injuries.

Do not walk on panels that have not been completely installed.

Do not walk on major ribs of panels.

Metal roofs that are wet or dusty can be extremely slippery. Wear soft soled shoes and a safety harness to minimize risk of falling.

Avoid installing metal panels in windy conditions.

Safety considerations are the responsibility of the installer and his crew. Be sure to and **use common sense** generally accepted safety practices when installing roofing materials.



Notes to Designer/Installer

Champion Metal is providing the following details as an aid in design. The details in this guide are not inclusive to all design situations. The designer/installer is responsible for modifications and should take into consideration all aspects of the project including climate conditions, such as, snow and wind, as well as, building code requirements, building design, building usage and maintenance requirements.

Installation should be performed only by qualified installers familiar with metal roofing systems and industry standards. For details not shown in this guide, refer to the Sheet Metal and Air Conditioning Contractors National Association (SMACNA) architectural sheet metal manual for proper design.

The Standard gauge for all products in this guide is 24 gauge and the standard finish is Kynar 500®/Hylar 5000®. We recommend specifying all flashings be the same gauge, color, and finish as the panels to insure long-term durability and color match.

Substrates

Details in the manual are all shown over solid substrate. **MS150** can be used over spaced purlins. For solid substrate, Champion Metal recommends 5/8" plywood or metal decking.

Underlayments

Minimum underlayment requirements are 30 lb. ASTM rated felt, a synthetic underlayment with Class A and ASTM UV protection technology or a high temperature self-adhering rubberized membrane. When choosing the underlayment, consider the roof slope, roof design, roof panel, and the climate.

Drag Load Requirements

All panels must be pinned at the top to resist the drag load caused by snow loads, live loads, and the weight of the panel. Drag load is a function of roof slope, actual load and length of panels. Contact Champion Metal for specific drag load requirements.



HOOK EAVE

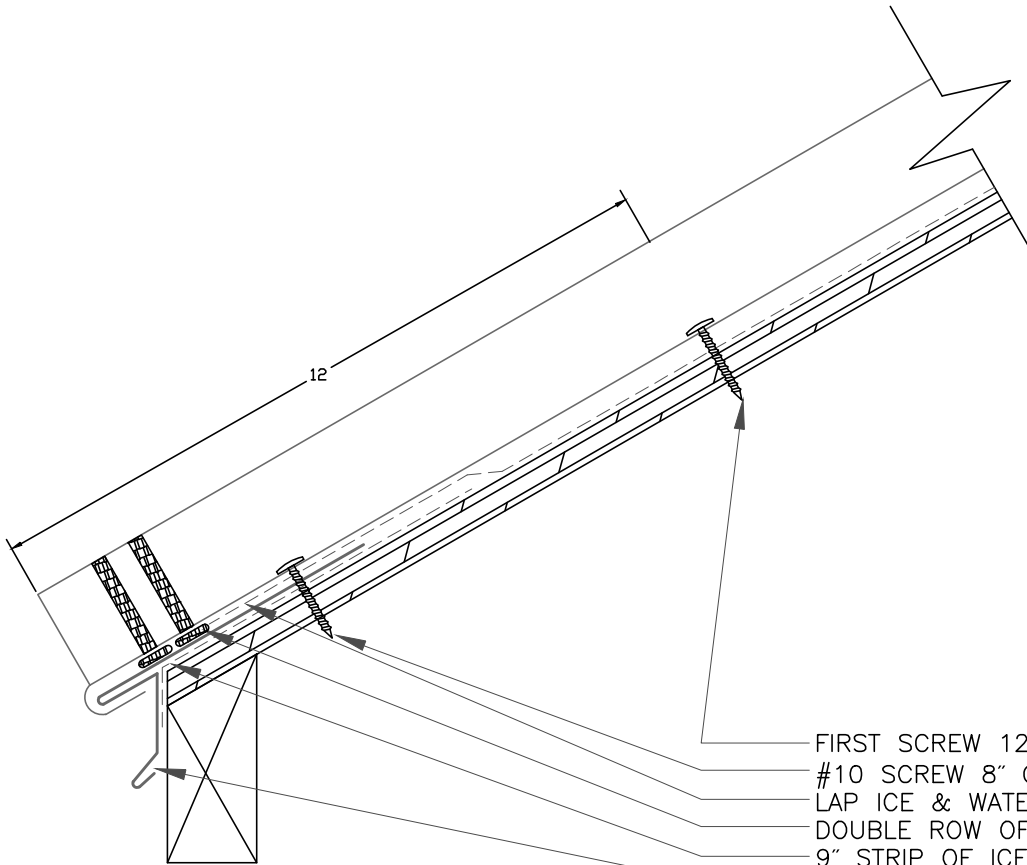

HOOK EAVE

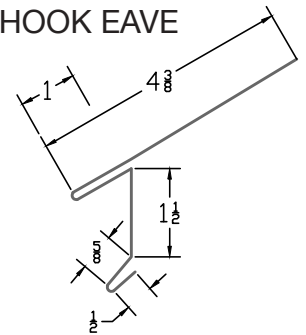

- FIRST SCREW 12" FROM EAVE INTO PANEL LEG
- #10 SCREW 8" OC INTO EAVE FLASHING
- LAP ICE & WATER OVER SCREW
- DOUBLE ROW OF NON-SKINNING GUNNABLE BUTYL
- 9" STRIP OF ICE & WATER UNDER EAVE
- HOOK EAVE

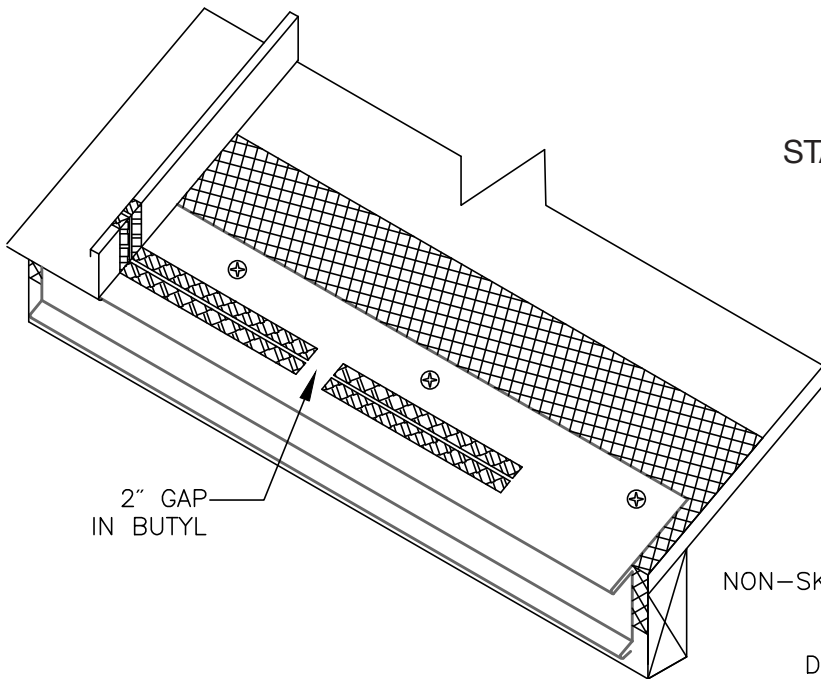

STANDARD EAVE

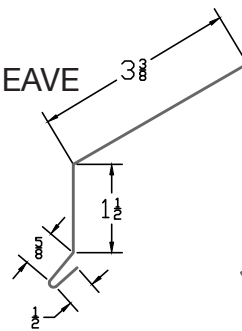

- NON-SKINNING GUNNABLE BUTYL
- INSIDE FOLD
- 22G OFFSET CLEAT
- DOUBLE BEAD BUTYL TAPE

NOTE: All screws must be into solid substrate.
Flashing must be lapped 4" with 2 rows of non-skinning gunnable butyl



BOX GUTTER

BOX GUTTER

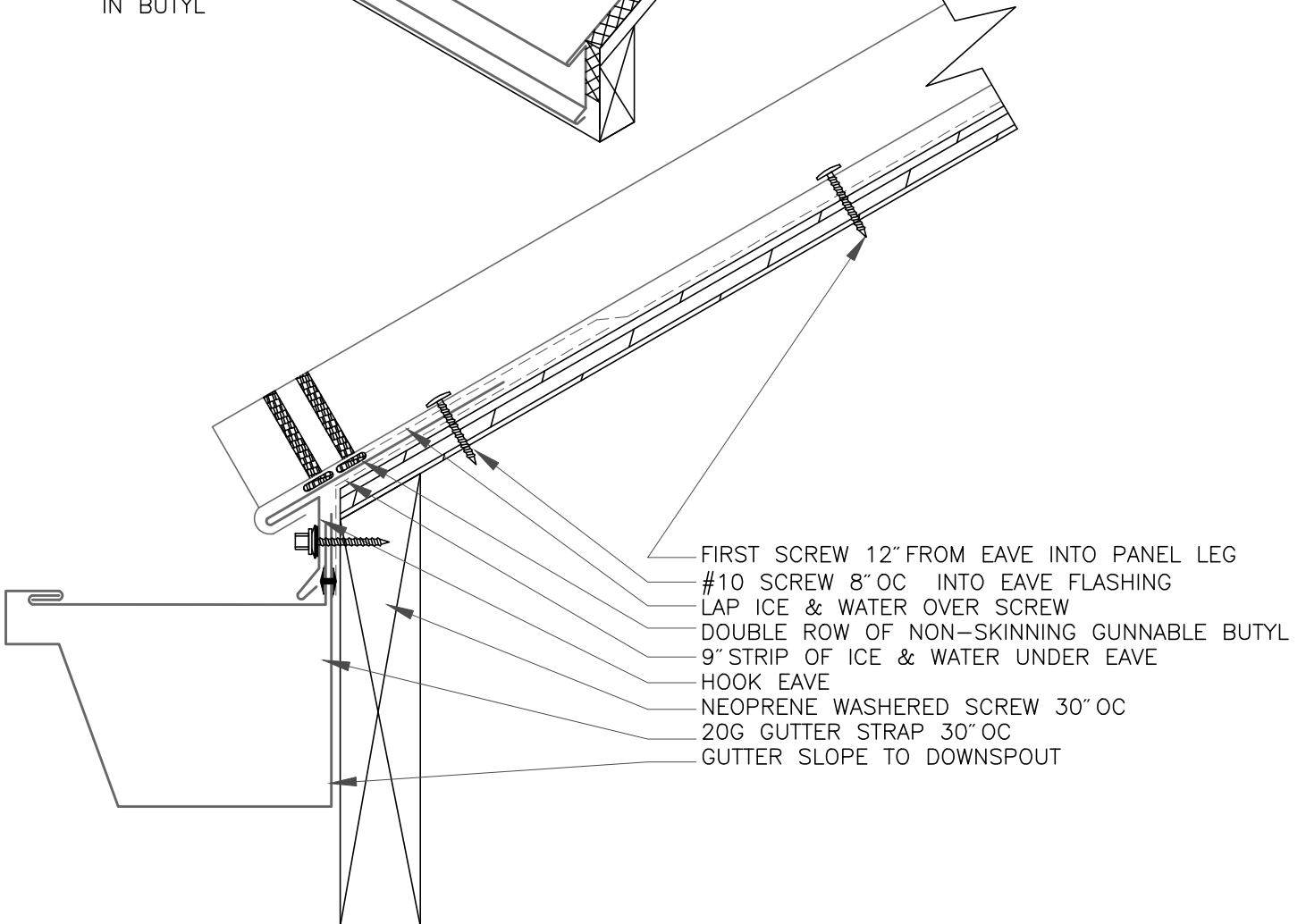
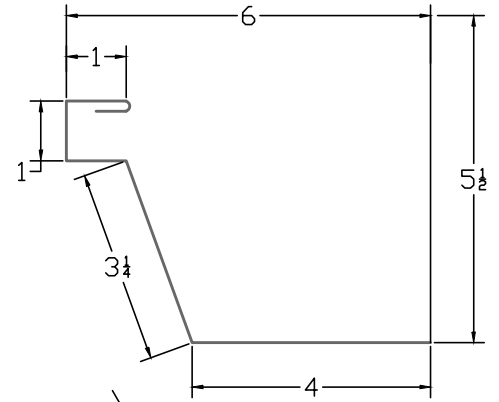
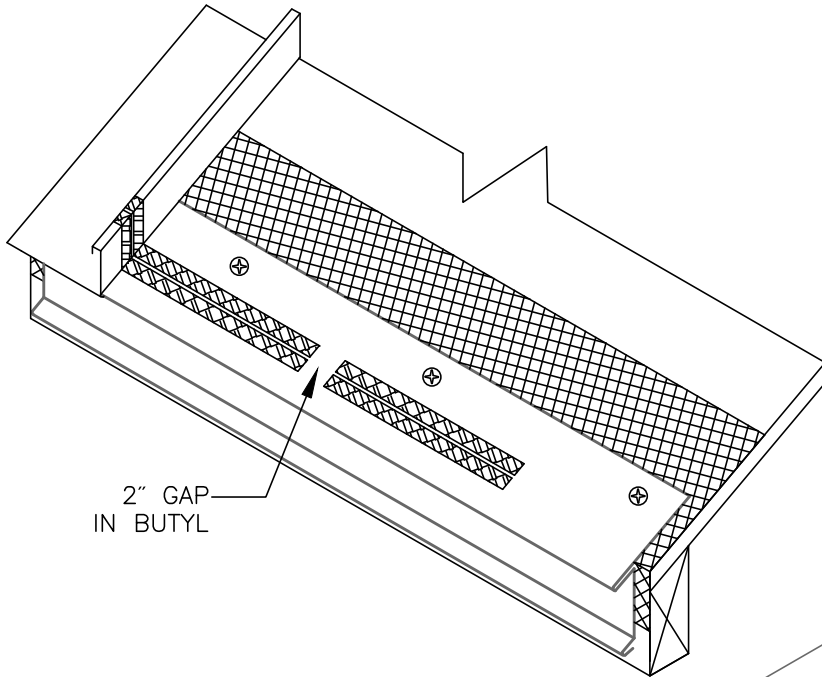

NOTE: All screws must be into solid substrate.
Flashing must be lapped 4" with 2 rows of non-skinning gunnable butyl



STANDARD RIDGE

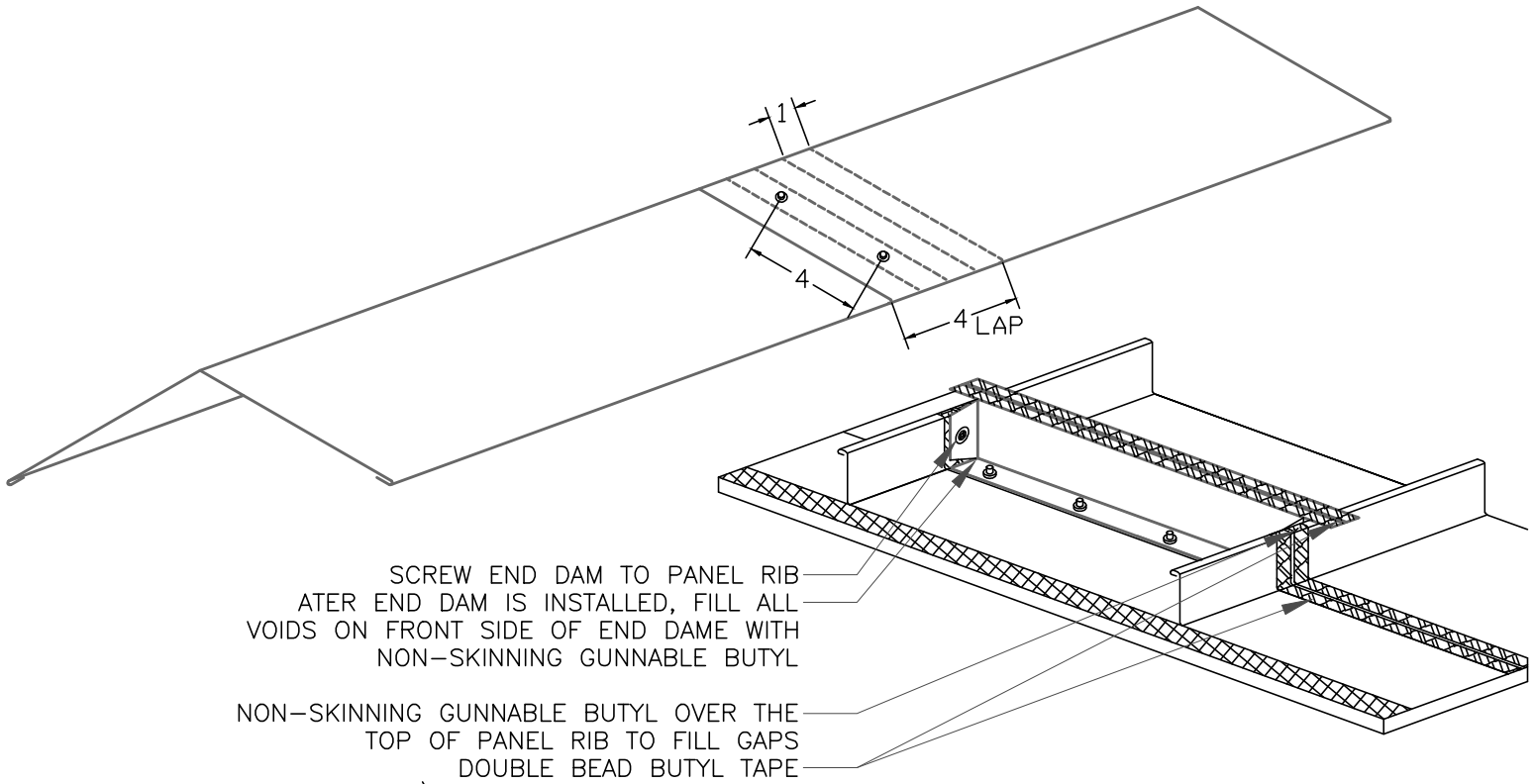

STANDARD RIDGE

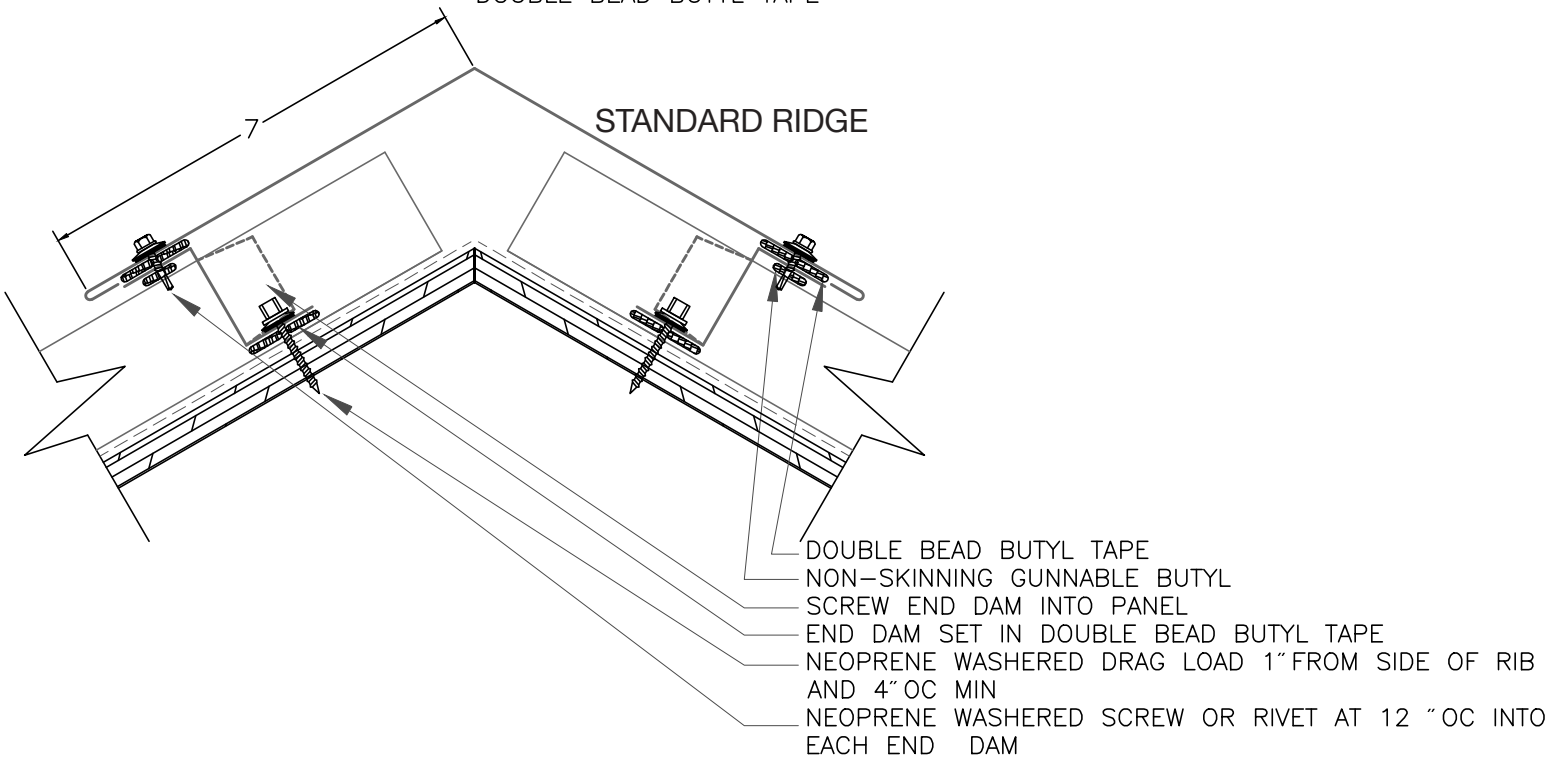

NOTE: All screws must be into solid substrate.
Flashing must be lapped 4" with 2 rows of non-skinning gunnable butyl



VENTED RIDGE

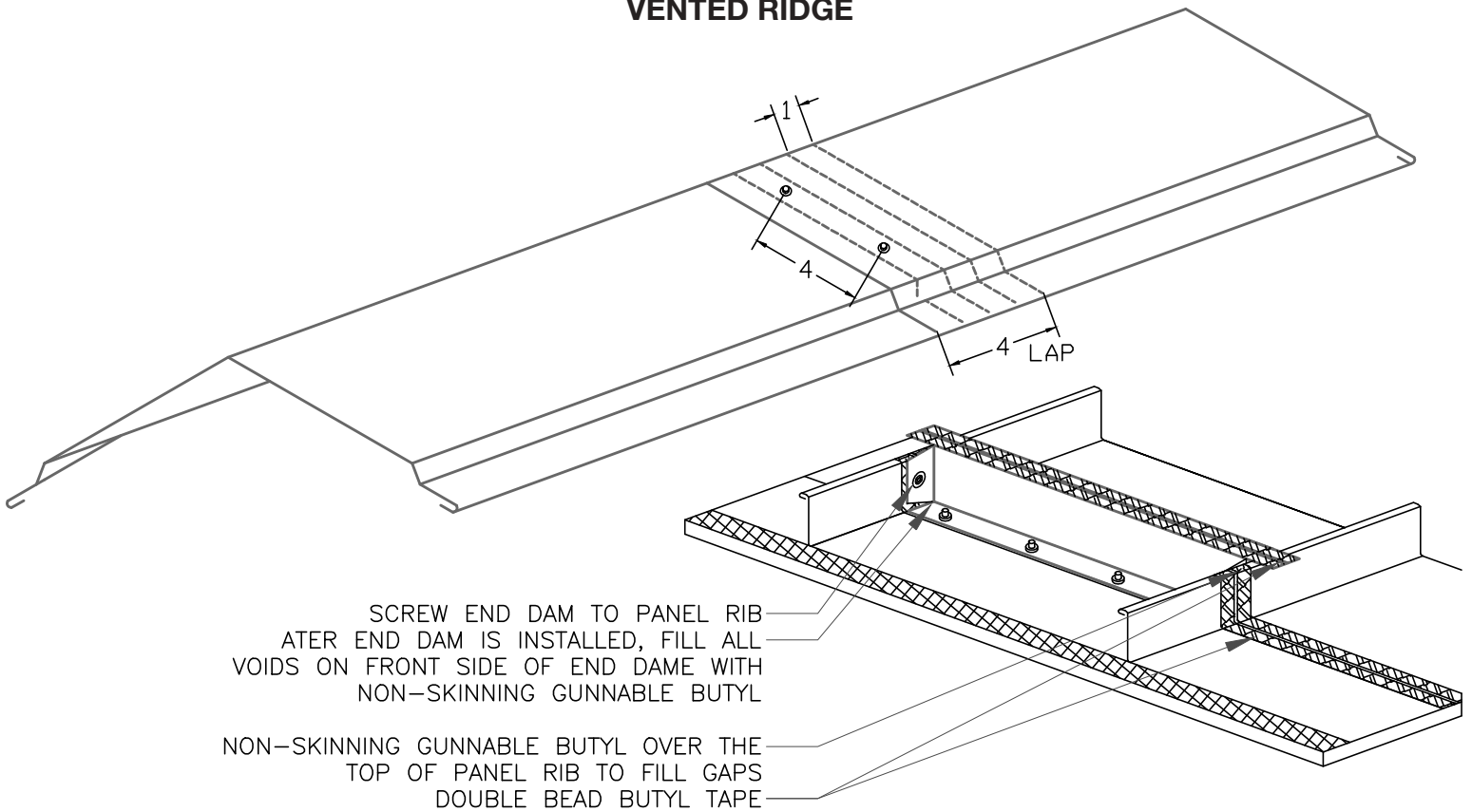

VENTED RIDGE

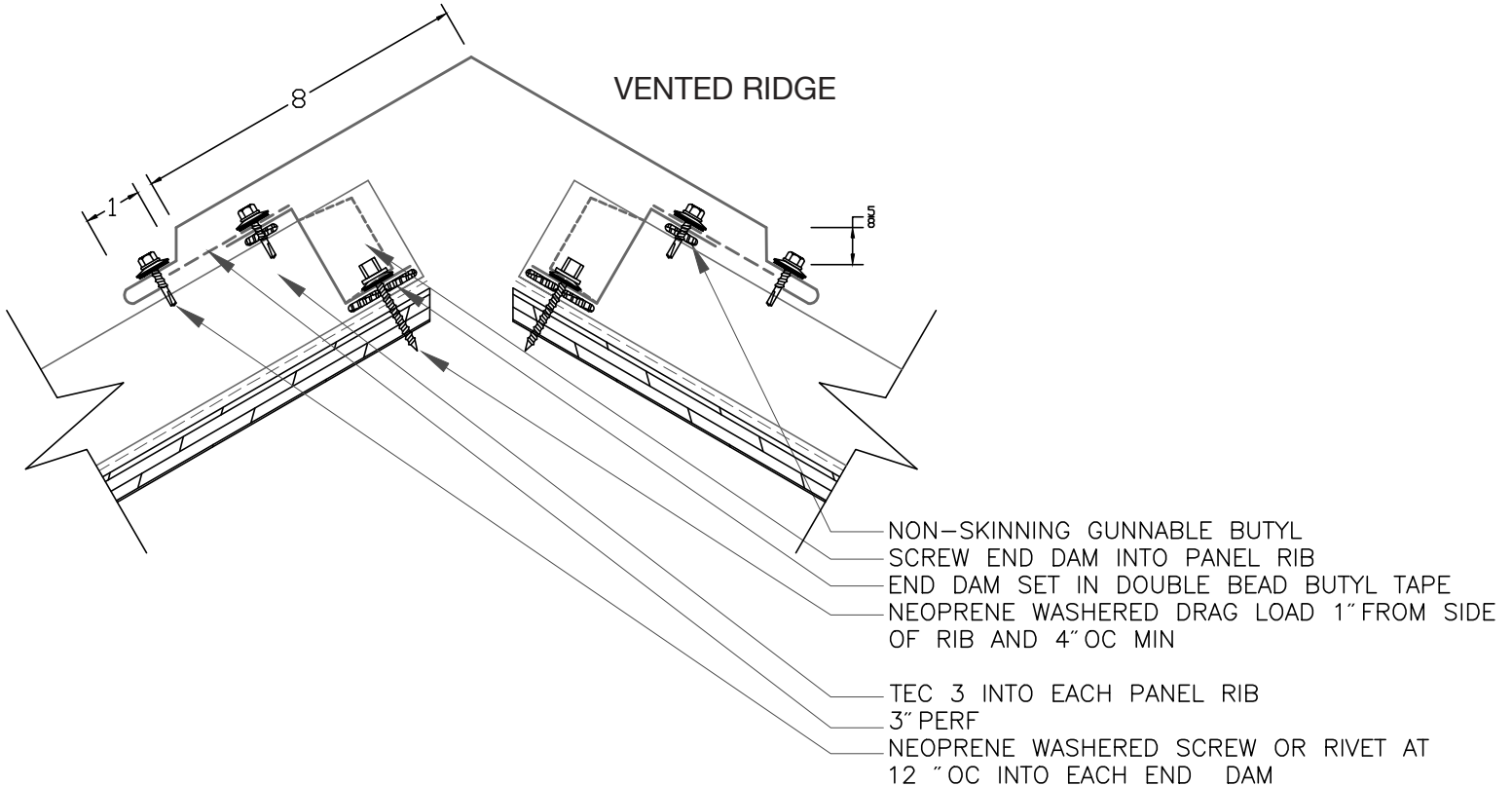

NOTE: All screws must be into solid substrate.
Flashing must be lapped 4" with 2 rows of non-skinning gunnable butyl



STANDARD VALLEY

3 ROWS OF NON-SKINNING GUNNABLE BUTYL AT LAP JOINT

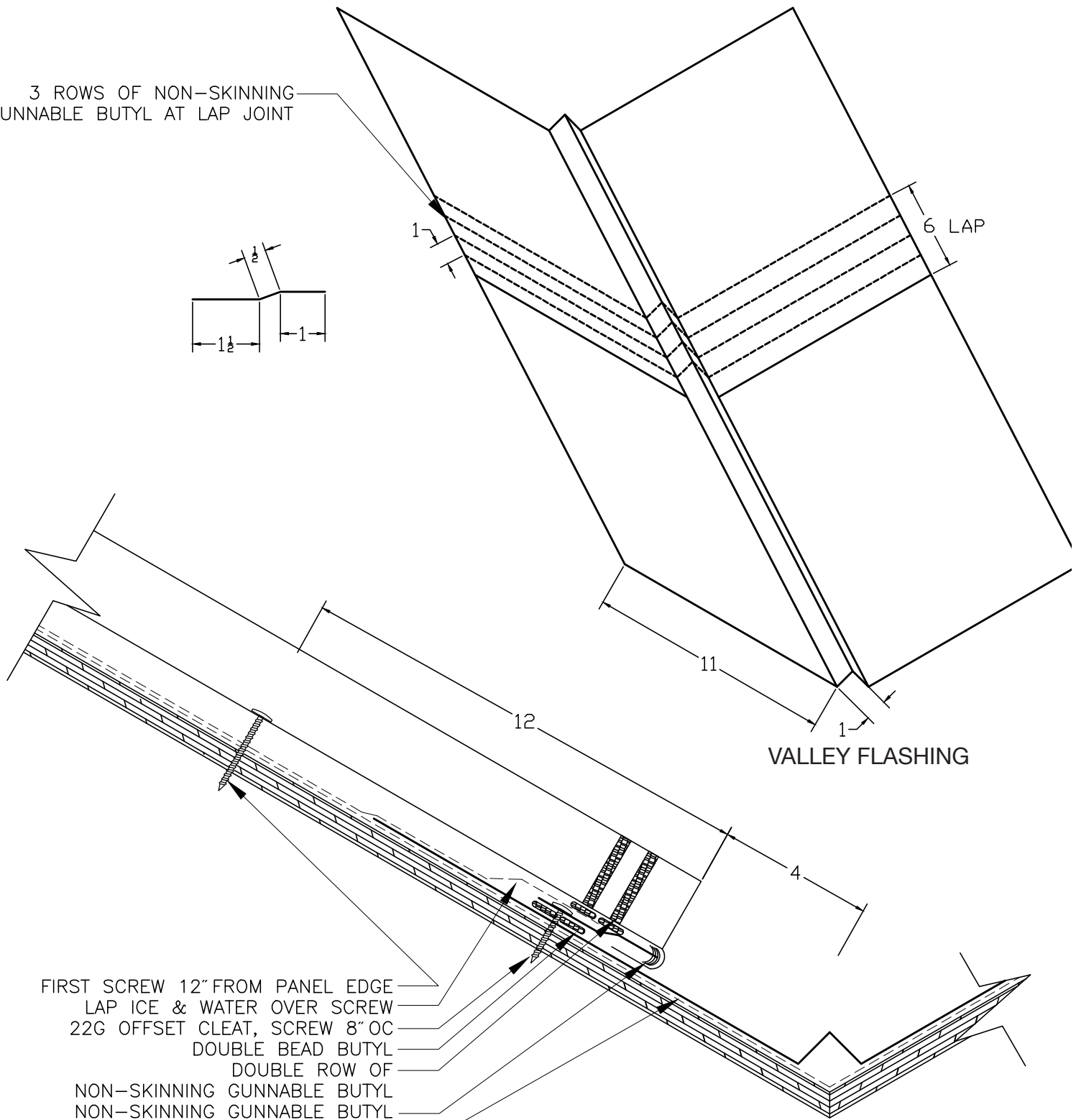
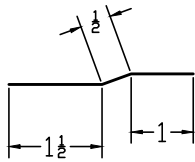

VALLEY FLASHING

- FIRST SCREW 12" FROM PANEL EDGE
- LAP ICE & WATER OVER SCREW
- 22G OFFSET CLEAT, SCREW 8" OC
- DOUBLE BEAD BUTYL
- DOUBLE ROW OF
- NON-SKINNING GUNNABLE BUTYL
- NON-SKINNING GUNNABLE BUTYL
- RUN ICE & WATER IN VALLEY

NOTE: All screws must be into solid substrate.
Flashing must be lapped 4" with 2 rows of non-skinning gunnable butyl



ALTERNATE VALLEY

3 ROWS OF NON-SKINNING GUNNABLE BUTYL AT LAP JOINT

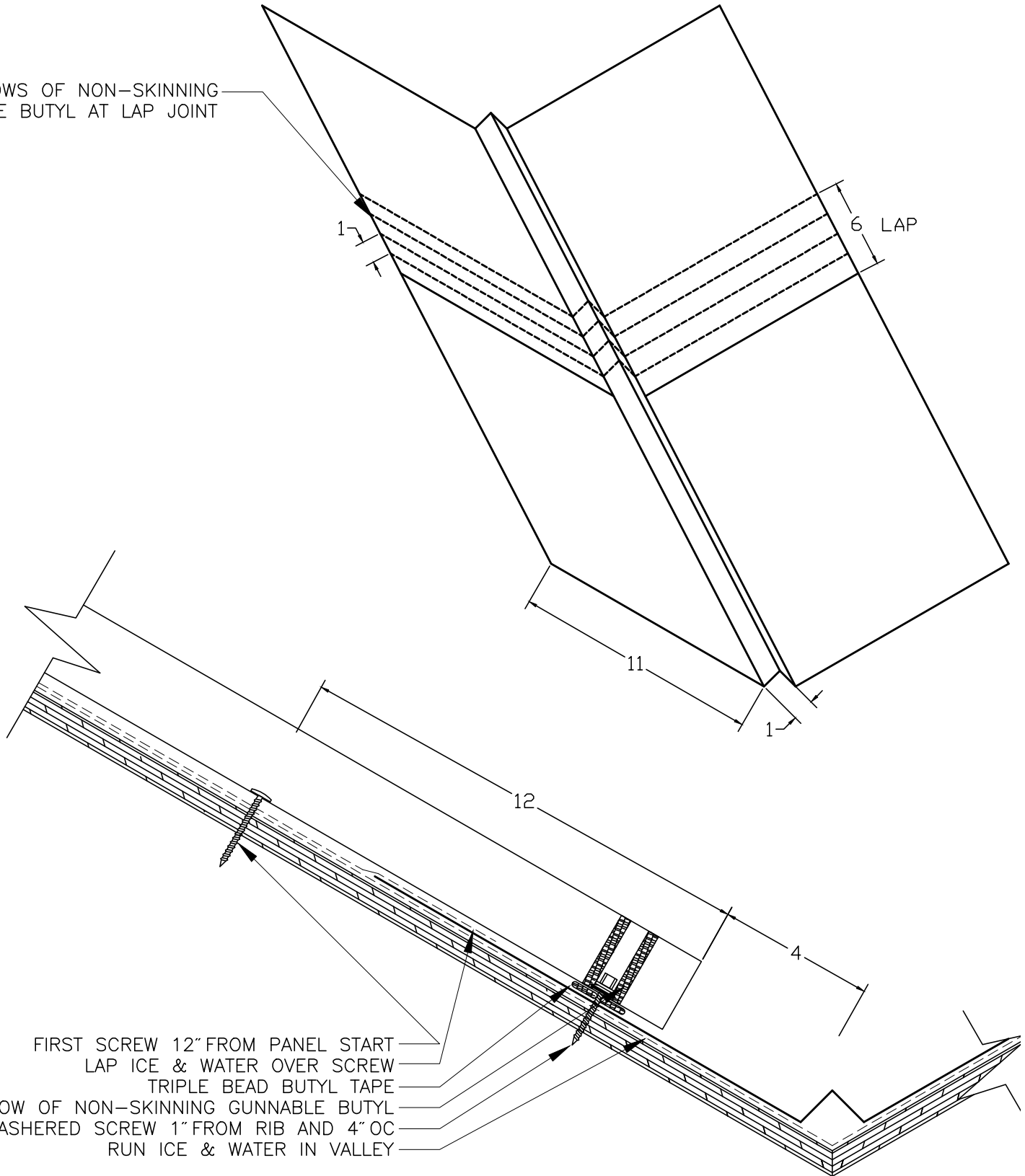

FIRST SCREW 12" FROM PANEL START
LAP ICE & WATER OVER SCREW
TRIPLE BEAD BUTYL TAPE
DOUBLE ROW OF NON-SKINNING GUNNABLE BUTYL
NEOPRENE WASHERED SCREW 1" FROM RIB AND 4" OC
RUN ICE & WATER IN VALLEY

NOTE: All screws must be into solid substrate.
Flashing must be lapped 4" with 2 rows of non-skinning gunnable butyl



STANDARD GABLE

SUPPORT FLASHING

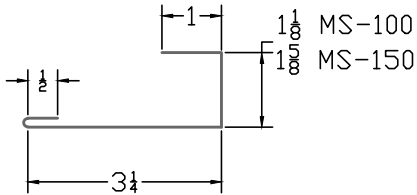

STANDARD GABLE

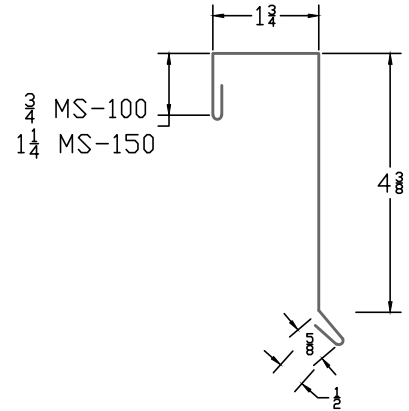

- NEOPRENE WASHERED SCREW OR RIVET 12" OC
- DOUBLE BEAD BUTYL TAPE
- SUPPORT FLASHING WITH BACK HEM
- SCREW 8" OC WITH SEALANT OVER THE TOP
- ICE & WATER WRAP DOWN FACE 3" MIN
- NEOPRENE WASHERED SCREW 12" OC

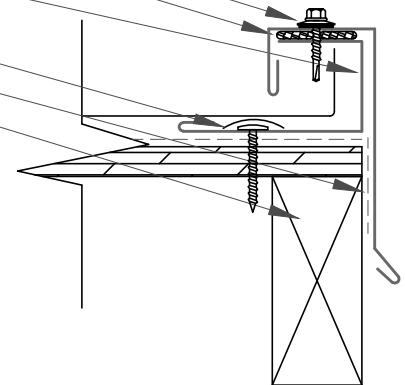

NOTE: All screws must be into solid substrate.
Flashing must be lapped 4" with 2 rows of non-skinning gunnable butyl



ALTERNATE GABLE

SUPPORT FLASHING

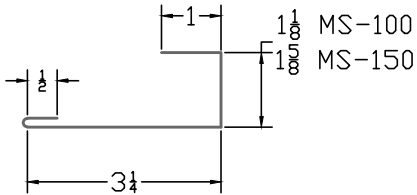

ALTERNATE GABLE L

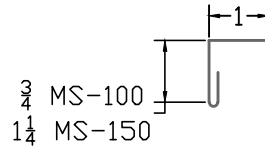

ALTERNATE GABLE

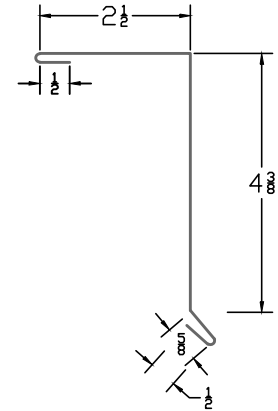

- NEOPRENE WASHERED SCREW 12" OC OR RIVET
- DOUBLE BEAD BUTYL TAPE
- CLOSURE TRIM
- SUPPORT FLASHING WITH BACK HEM
- CONTINUOUS CLEAT
- SCREW 8" OC WITH SEALANT OVER THE TOP
- ICE AND WATER WRAP DOWN FACE 3" MIN
- CLEAT SCREW 8" OC

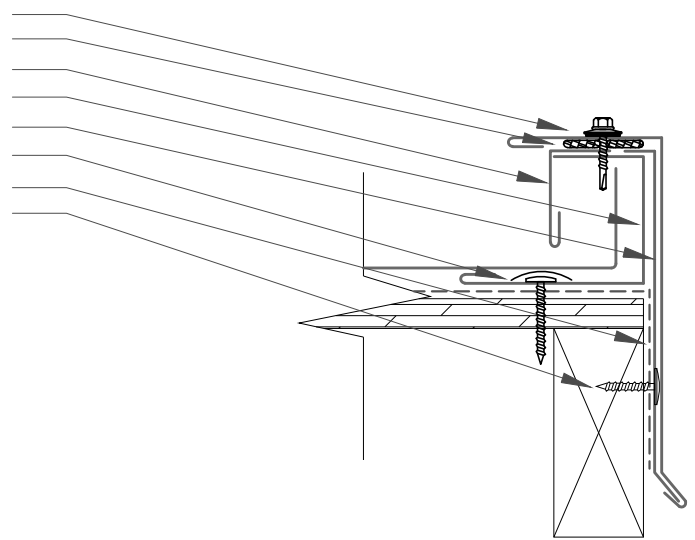

NOTE: All screws must be into solid substrate.
Flashing must be lapped 4" with 2 rows of non-skinning gunnable butyl



SIDE WALL

SUPPORT FLASHING

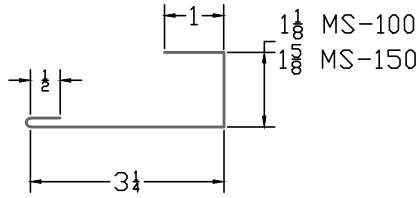

SIDE WALL

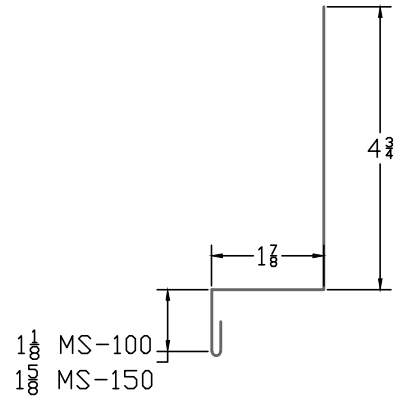

- LAP UNDERLAYMNET OVER SCREW
- ICE & WATER TURN UP WALL 8"
- NEOPRNE WASHERED SCREW OR RIVET 12" OC
- DOUBLE BEAD BUTYL TAPE
- CLOSURE TRIM
- SUPPORT FLASHING WITH BACK HEM
- SCREW 8" OC WITH SEALANT OVER THE TOP

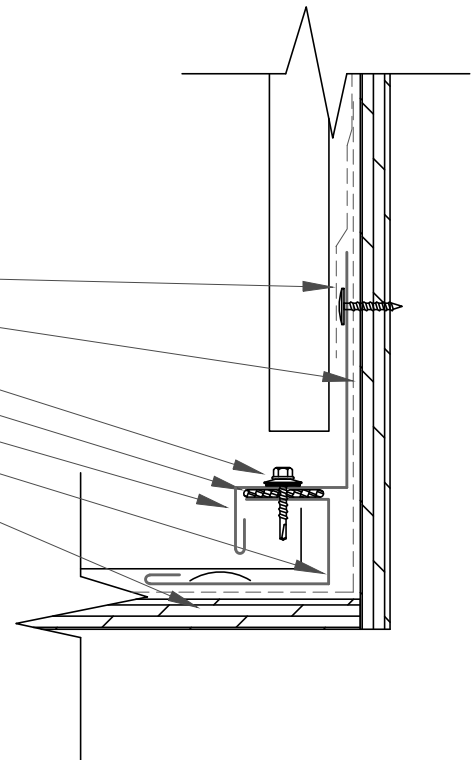



RIDGE END CAP

3 ROWS OF NON-SKINNING GUNNABLE BUTYL AT LAP JOINT
NEOPRENE WASHERED SCREW 4" OC

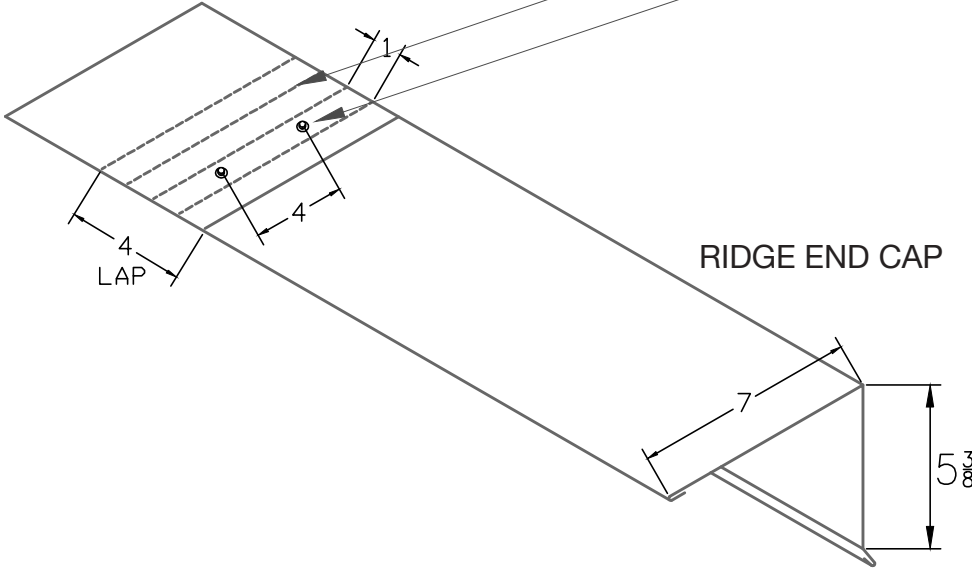

RIDGE END CAP

SCREW END DAM TO PANEL RIB
AFTER END DAM IS INSTALLED, FILL ALL
VOIDS ON FRONT SIDE OF END DAME WITH
NON-SKINNING GUNNABLE BUTYL

NON-SKINNING GUNNABLE BUTYL OVER THE
TOP OF PANEL RIB TO FILL GAPS
DOUBLE BEAD BUTYL TAPE

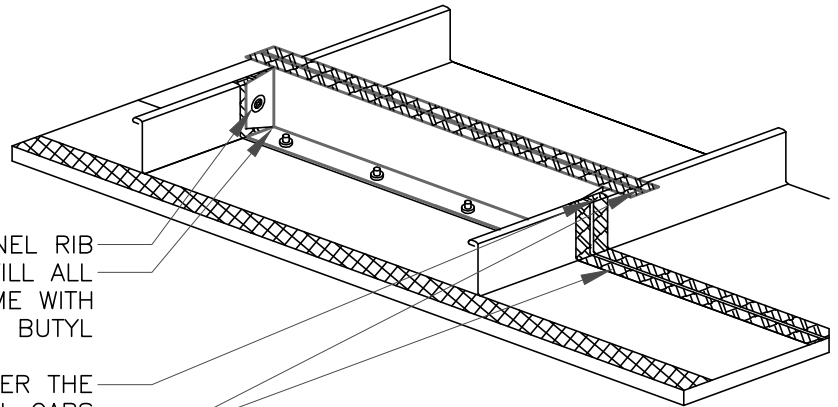

END RIDGE CAP
CONTINUOUS SUPPORT CLEAT
NEOPRENE WASHERED SCREW OR RIVET AT 12" OC
INTO EACH END DAM
DOUBLE BEAD BUTYL TAPE
NON-SKINNING GUNNABLE BUTYL
SCREW END DAM TO PANEL RIB
END DAM SET IN DOUBLE BEAD BUTYL TAPE
NEOPRENE WASHERED SCREW 1" FROM SIDE OF RIB
AND 4" OC MIN
CLEAT SCREW 8" OC

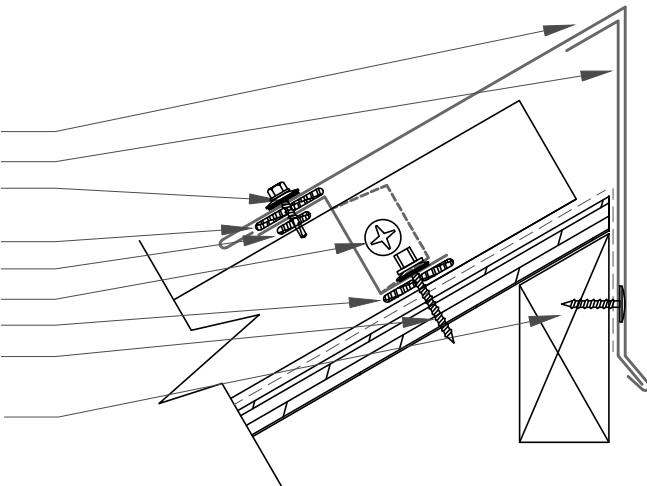



VENTED RIDGE END CAP

3 ROWS OF NON-SKINNING GUNNABLE BUTYL AT LAP JOINT
NEOPRENE WASHERED SCREW 4" OC

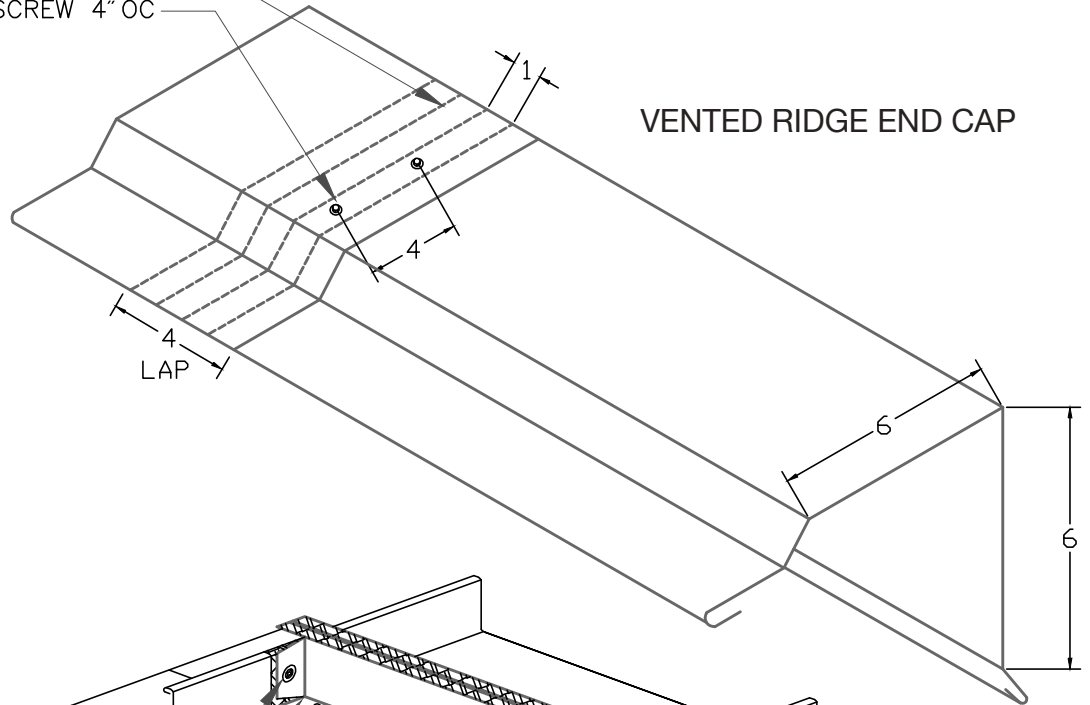

VENTED RIDGE END CAP

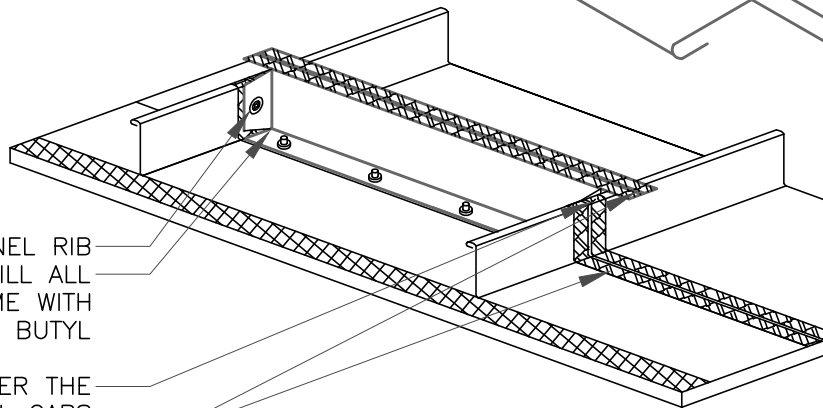

SCREW END DAM TO PANEL RIB
AFTER END DAM IS INSTALLED, FILL ALL
VOIDS ON FRONT SIDE OF END DAME WITH
NON-SKINNING GUNNABLE BUTYL

NON-SKINNING GUNNABLE BUTYL OVER THE
TOP OF PANEL RIB TO FILL GAPS
DOUBLE BEAD BUTYL TAPE

END RIDGE CAP
CONTINUOUS CLEAT
NON-SKINNING GUNNABLE BUTYL
3" PERF
TEC 3 SCREW INTO PANEL RIB
NEOPRENE WASHED SCREW 1" FROM SIDE OF RIB AND 4"
OC MIN
CLEAT SCREW 8" OC

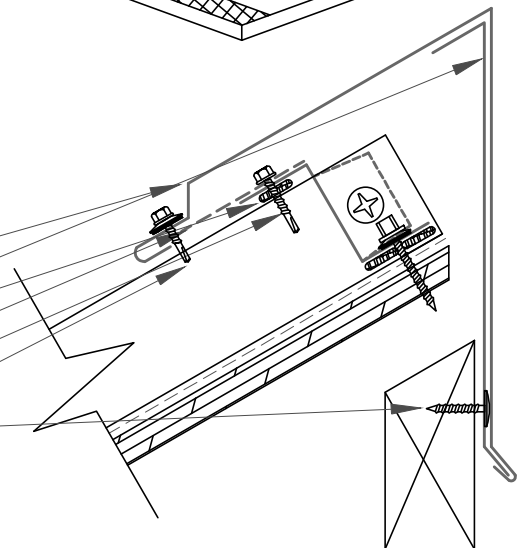



PITCH CHANGE

3 ROWS OF NON-SKINNING GUNNABLE BUTYL AT LAP JOINT
NEOPRENE WASHERED SCREW 4" OC

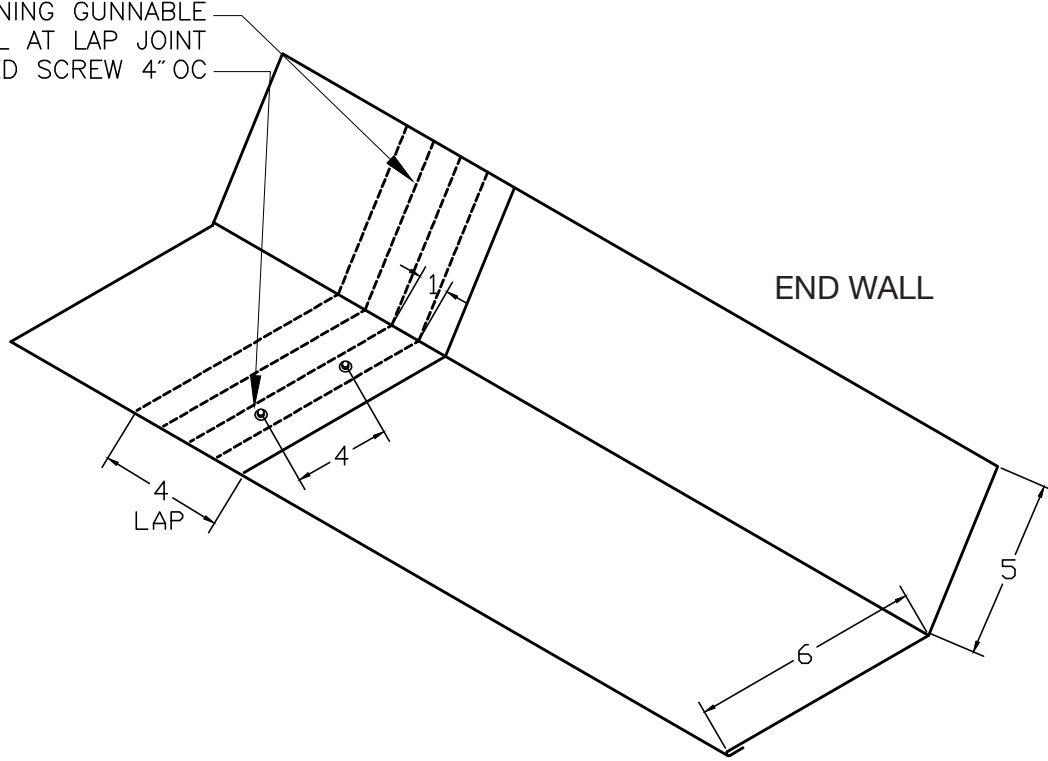

#10 SCREW 8" OC
LAP ICE & WATER OVER SCREW
DOUBLE ROW OF NON-SKINNING GUNNABLE BUTYL
22G OFFSET CLEAT
NON-SKINNING GUNNABLE BUTYL UNDER PANEL HOOK
SCREW END DAM TO PANEL RIB
NEOPRENE WASHERED DRAG LOAD 1" FROM SIDE OF RIB AND 4" OC MIN

END DAM SET IN DOUBLE BEAD BUTYL TAPE
NEOPRENE WASHERED SCREW OF RIVET AT 12" OC INTO EACH END DAM
NON-SKINNING GUNNABLE BUTYL
DOUBLE BEAD BUTYL TAPE

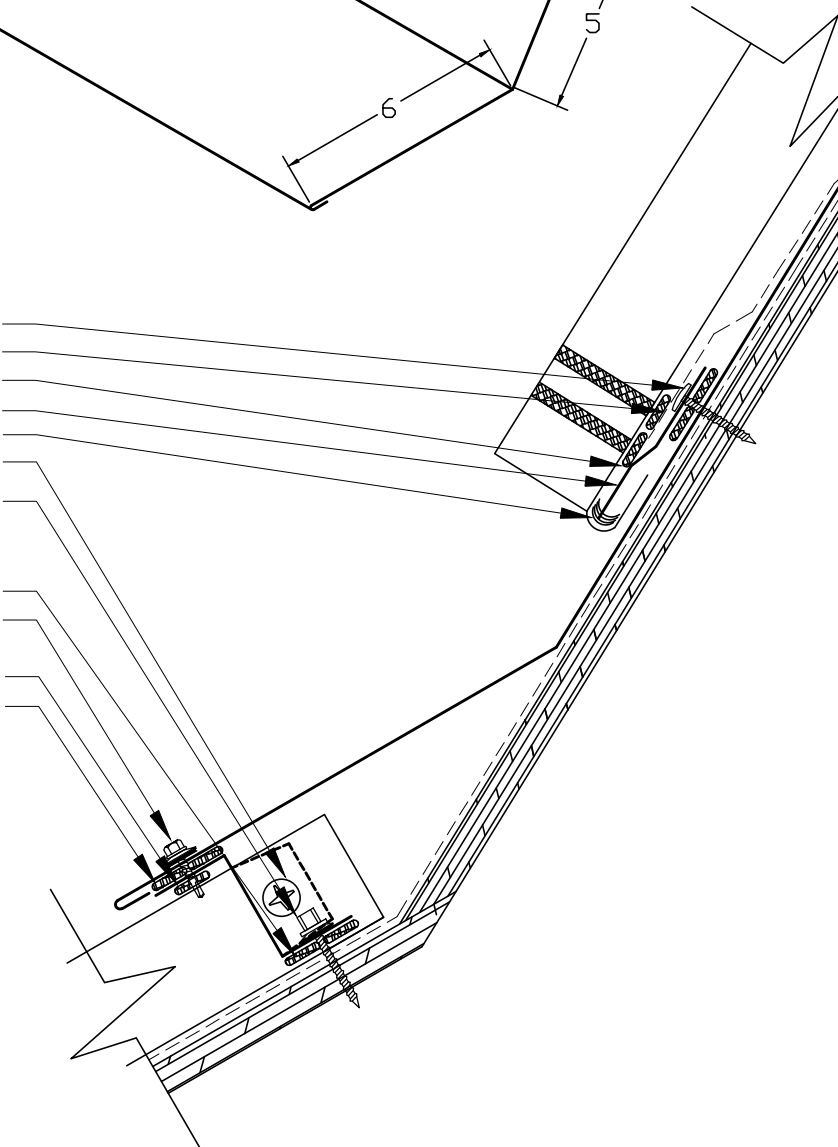



END WALL

3 ROWS OF NON-SKINNING GUNNABLE BUTYL AT LAP JOINT
NEOPRENE WASHERED SCREW 4" OC

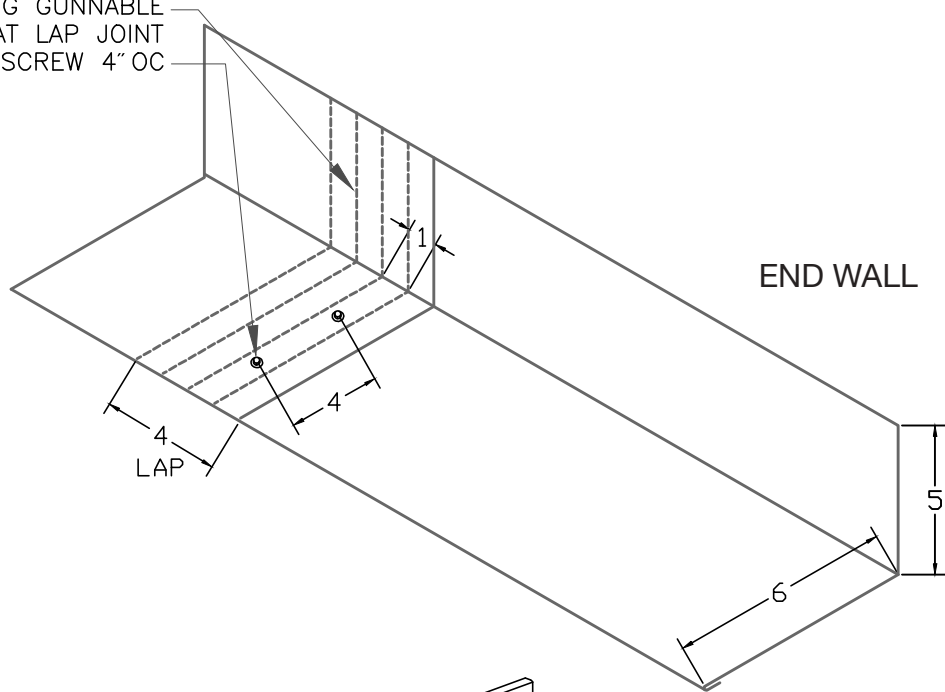

SCREW END DAM TO PANEL RIB
AFTER END DAM IS INSTALLED, FILL ALL VOIDS ON FRONT SIDE OF END DAME WITH NON-SKINNING GUNNABLE BUTYL

NON-SKINNING GUNNABLE BUTYL OVER THE TOP OF PANEL RIB TO FILL GAPS
DOUBLE BEAD BUTYL TAPE

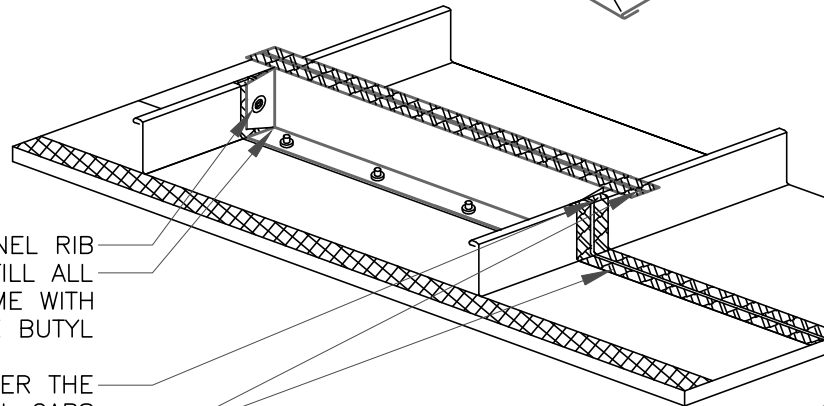

LAP UNDERLAYMENT OVER SCREW
ICE & WATER UP WALL 8"
NEOPRENE WASHERED SCREW OR RIVET AT 12" OC INTO EACH END DAM
DOUBLE BEAD BUTYL TAPE
NON-SKINNING GUNNABLE BUTYL
SCREW END DAM TO PANEL RIB
END DAM SET IN DOUBLE BEAD BUTYL TAPE
NEOPRENE WASHERED SCREW 1" FROM SIDE OF RIB AND 4" OC MIN
DOUBLE BEAD BUTYL TAPE

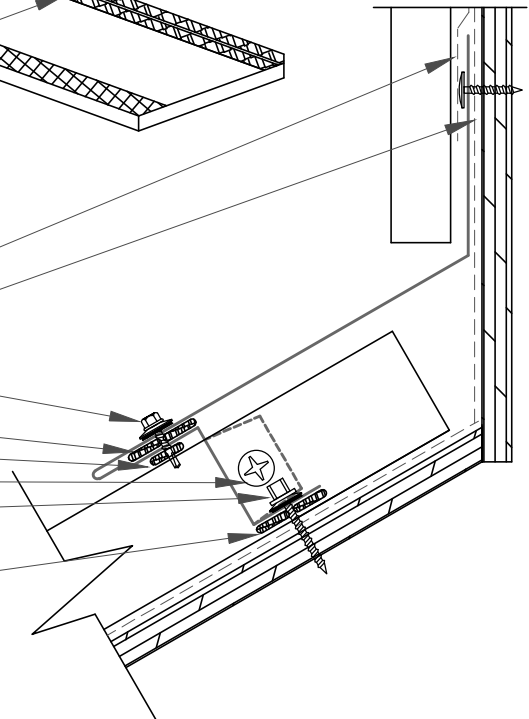



VENTED END WALL

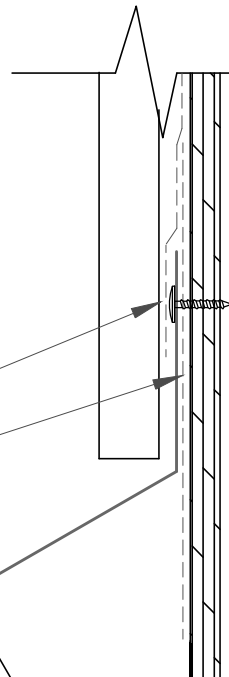
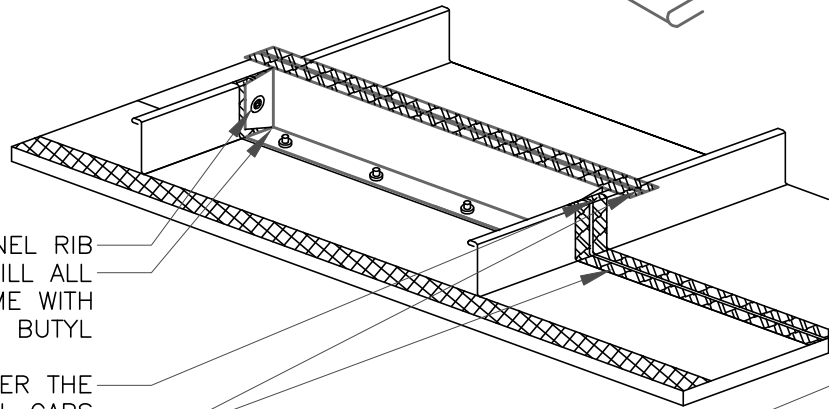
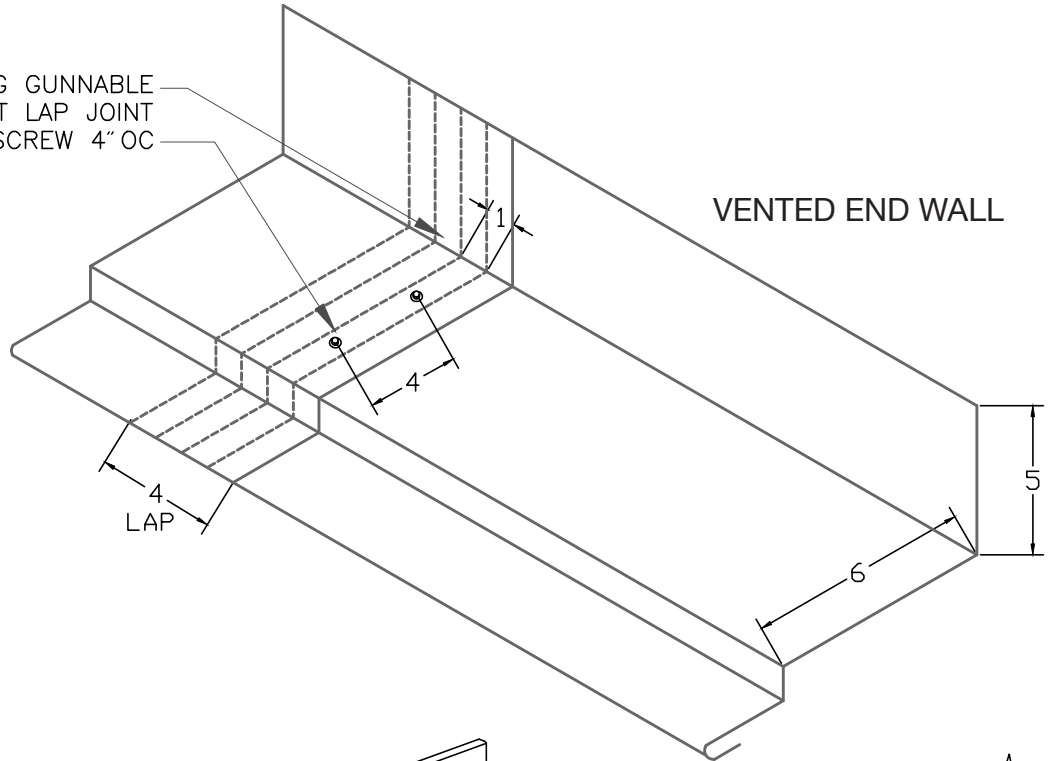

- LAP UNDERLAYMENT OVER SCREW
- ICE & WATER UP WALL 8"
- NEOPRENE WASHERED SCREW OR RIVET AT 12" OC INTO EACH END DAM
- NON-SKINNING GUNNABLE BUTYL ON TOP OF RIB
- SCREW END DAM TO PANEL RIB
- END DAM SET IN DOUBLE BEAD BUTYL TAPE
- NEOPRENE WASHERED SCREW 1" FROM SIDE OF RIB AND 4" OC MIN
- 3" PERF
- NEOPRENE WASHERED SCREW AT 12" OC
- DOUBLE BEAD BUTYL TAPE

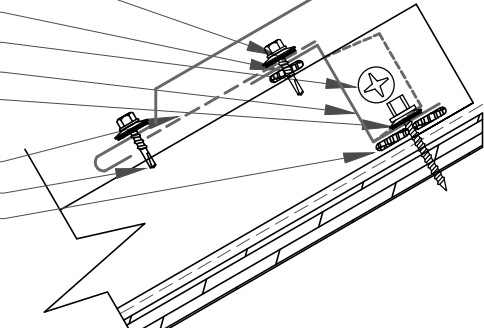



BACK PAN

BACK PAN
CURB WIDTHS LESS THAN 24"

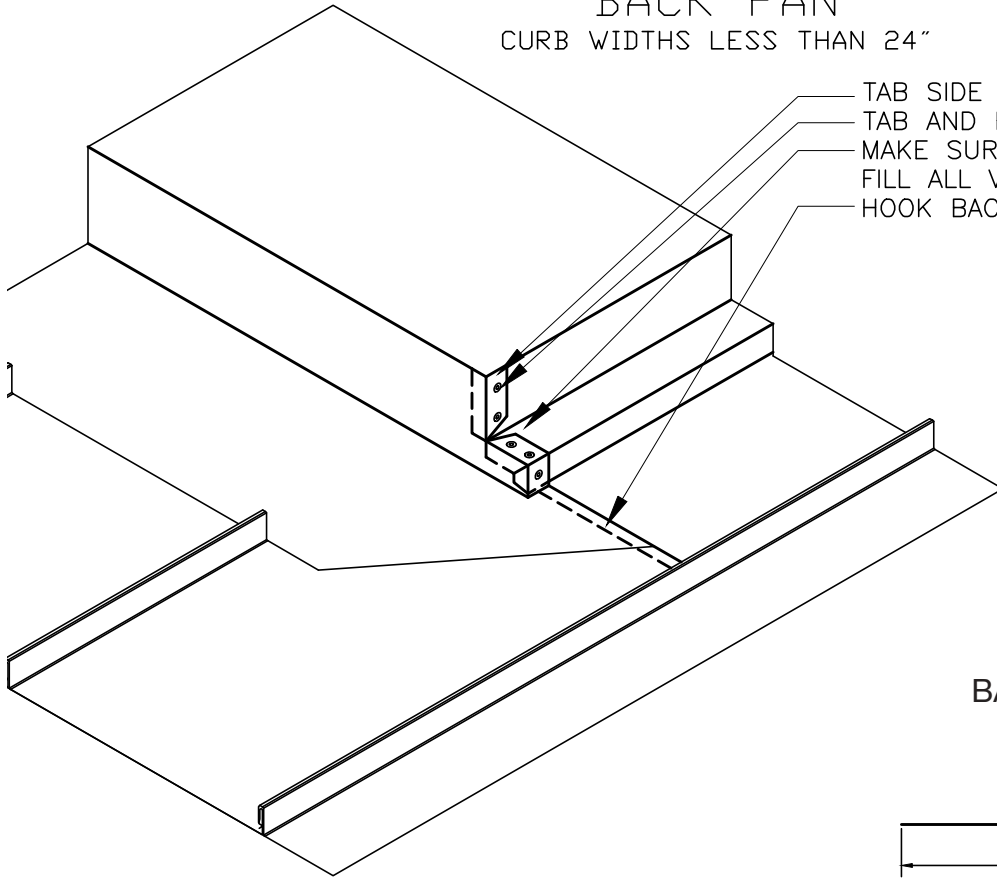

- TAB SIDE WALL TO RECIEVE BACK PAN
- TAB AND RIVET BACK PAN
- MAKE SURE END DAM UNDER SIDE WALL IS SEALED, FILL ALL VOIDS WITH NON-SKINNING GUNNABLE BUTYL
- HOOK BACK PAN TO OFFSET CLEAT

BACK PAN

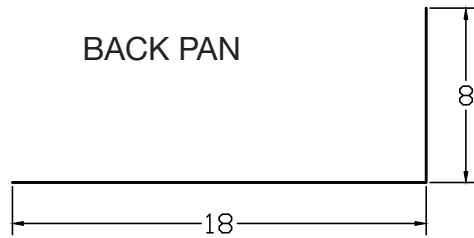

SOLDERED BACK PAN
CURB GREATER THAN 24"

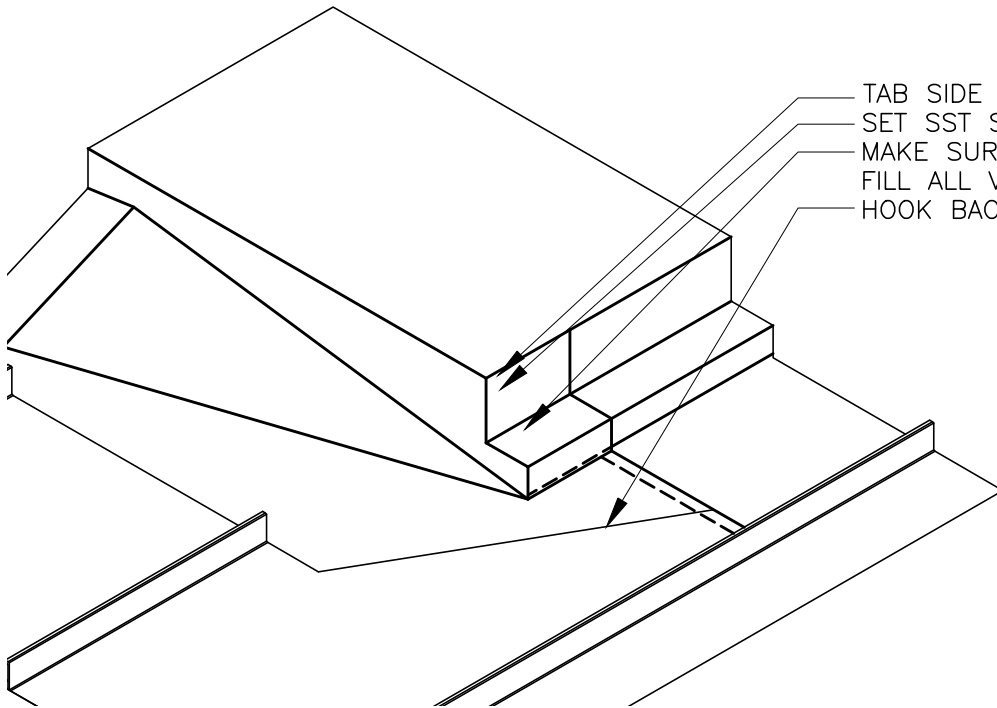

- TAB SIDE WALL TO RECIEVE BACK PAN
- SET SST SOLDERED PAN IN NON-SKINNING BUTYL
- MAKE SURE END DAM UNDER SIDE WALL IS SEALED, FILL ALL VOIDS WITH NON-SKINNING GUNNABLE BUTYL
- HOOK BACK PAN TO OFFSET CLEAT



CURB SIDE WALL

CLOSURE ZEE

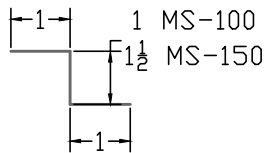

CURB SIDE WALL

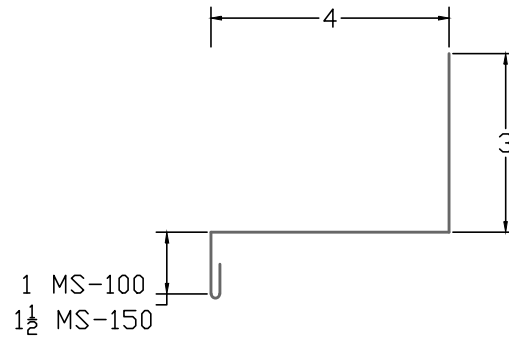

- LAP UNDERLAYMENT OVER SCREW
- ICE & WATER TURN UP WALL 8"
- NEOPRENE WASHERED SCREW OR RIVET 12" OC
- DOUBLE BEAD BUTYL TAPE
- CLOSURE TRIM
- ZEE
- DOUBLE BEAD BUTYL TAPE
- NEOPRENE WASHERED SCREW 8" OC
- TURN SIDE OF PANEL UP

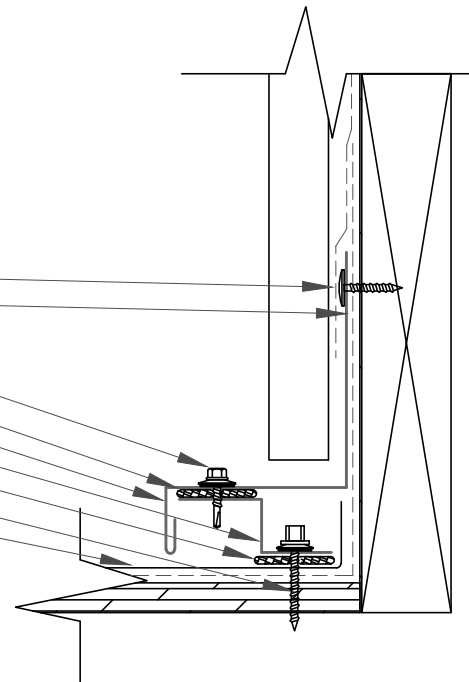



CURB HEAD

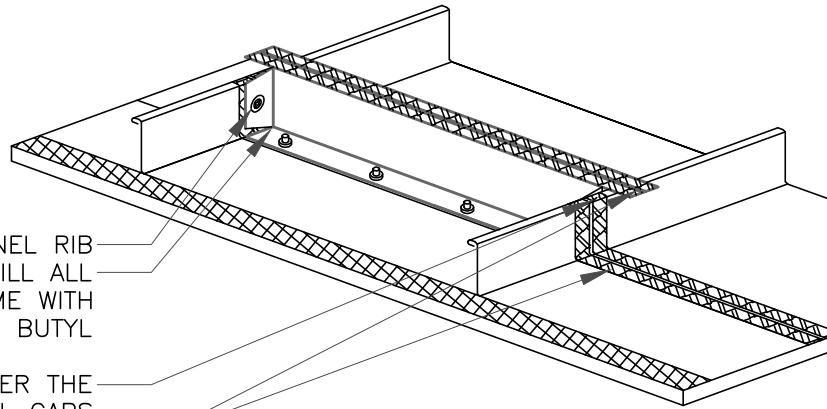

SCREW END DAM TO PANEL RIB
AFTER END DAM IS INSTALLED, FILL ALL
VOIDS ON FRONT SIDE OF END DAME WITH
NON-SKINNING GUNNABLE BUTYL

NON-SKINNING GUNNABLE BUTYL OVER THE
TOP OF PANEL RIB TO FILL GAPS
DOUBLE BEAD BUTYL TAPE

CURB HEAD

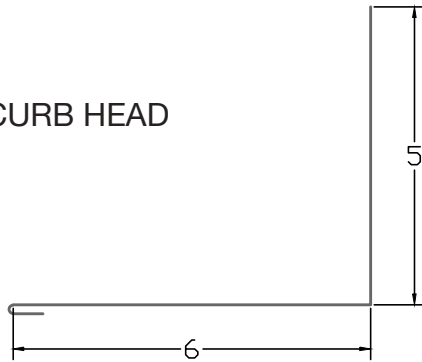

LAP UNDERLAYMENT OVER SCREW
ICE & WATER UP WALL 8"
NEOPRENE WASHERED SCREW OR RIVET AT 12" OC
INTO EACH END DAM
DOUBLE BEAD BUTYL TAPE
NON-SKINNING GUNNABLE BUTYL
SCREW END DAM TO PANEL RIB
END DAM SET IN DOUBLE BEAD BUTYL TAPE
NEOPRENE WASHERED SCREW 1" FROM SIDE OF RIB
AND 4" OC MIN
DOUBLE BEAD BUTYL TAPE

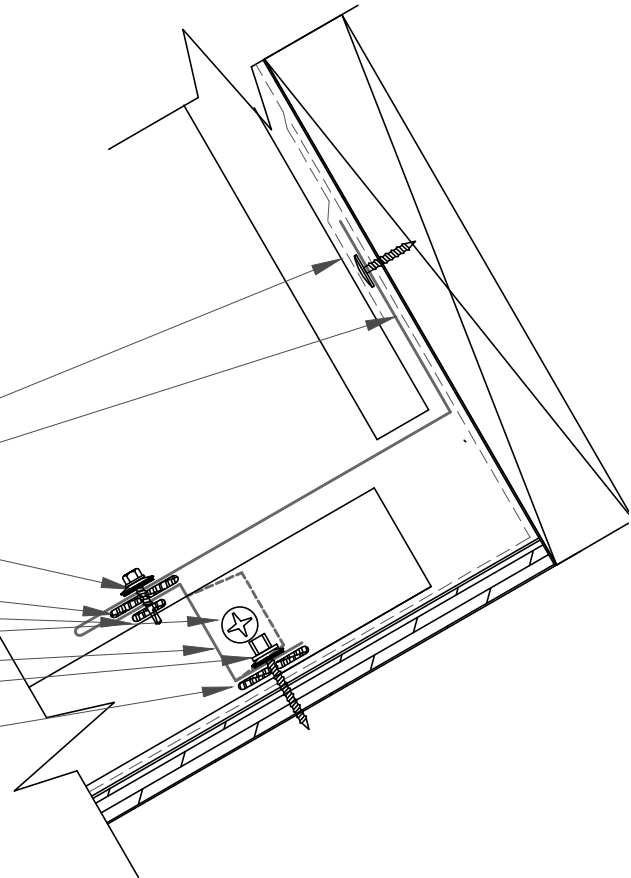



CURB BACK PAN

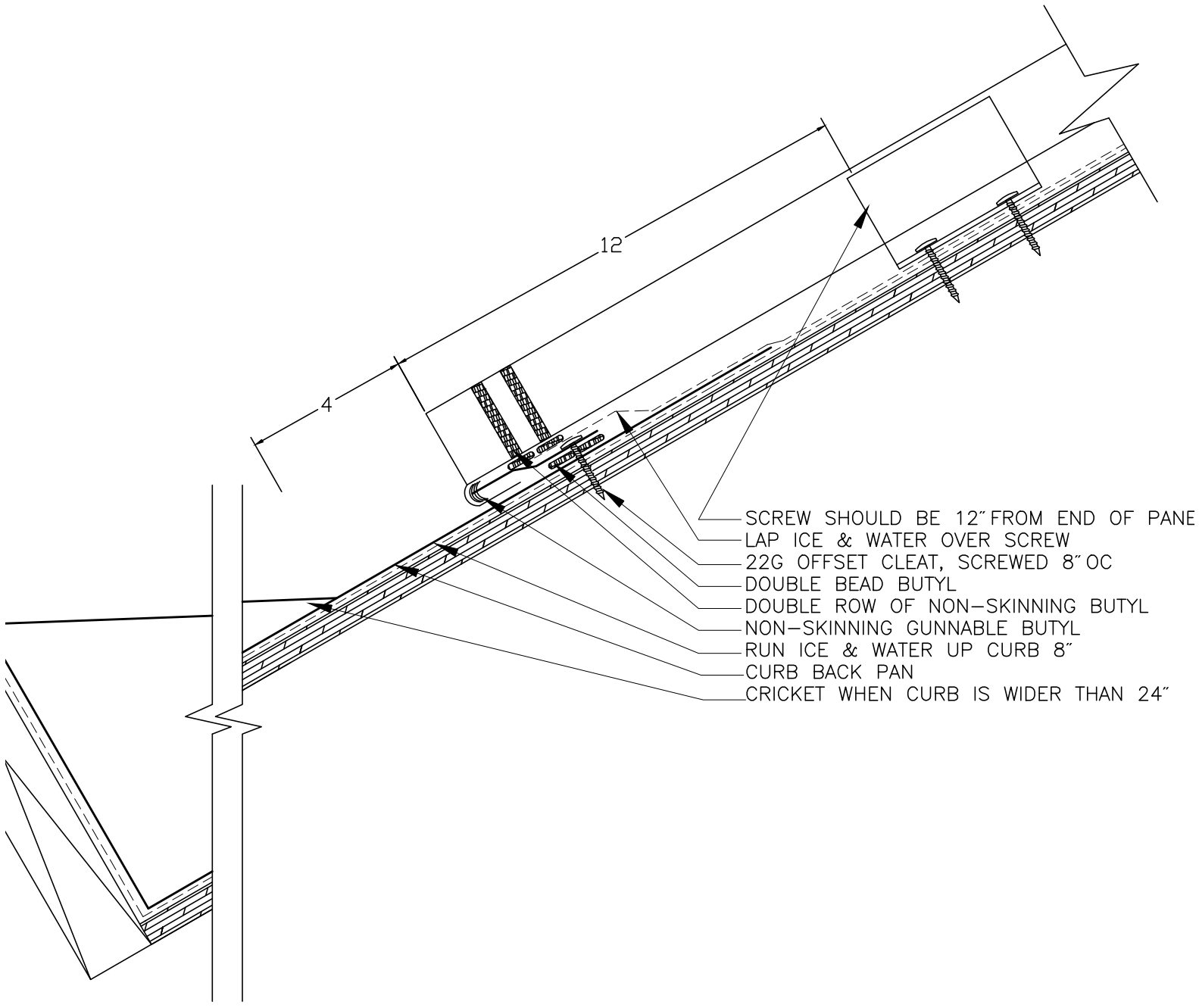

- SCREW SHOULD BE 12" FROM END OF PANE
- LAP ICE & WATER OVER SCREW
- 22G OFFSET CLEAT, SCREWED 8" OC
- DOUBLE BEAD BUTYL
- DOUBLE ROW OF NON-SKINNING BUTYL
- NON-SKINNING GUNNABLE BUTYL
- RUN ICE & WATER UP CURB 8"
- CURB BACK PAN
- CRICKET WHEN CURB IS WIDER THAN 24"



PIPE PENETRATION

STEP 1

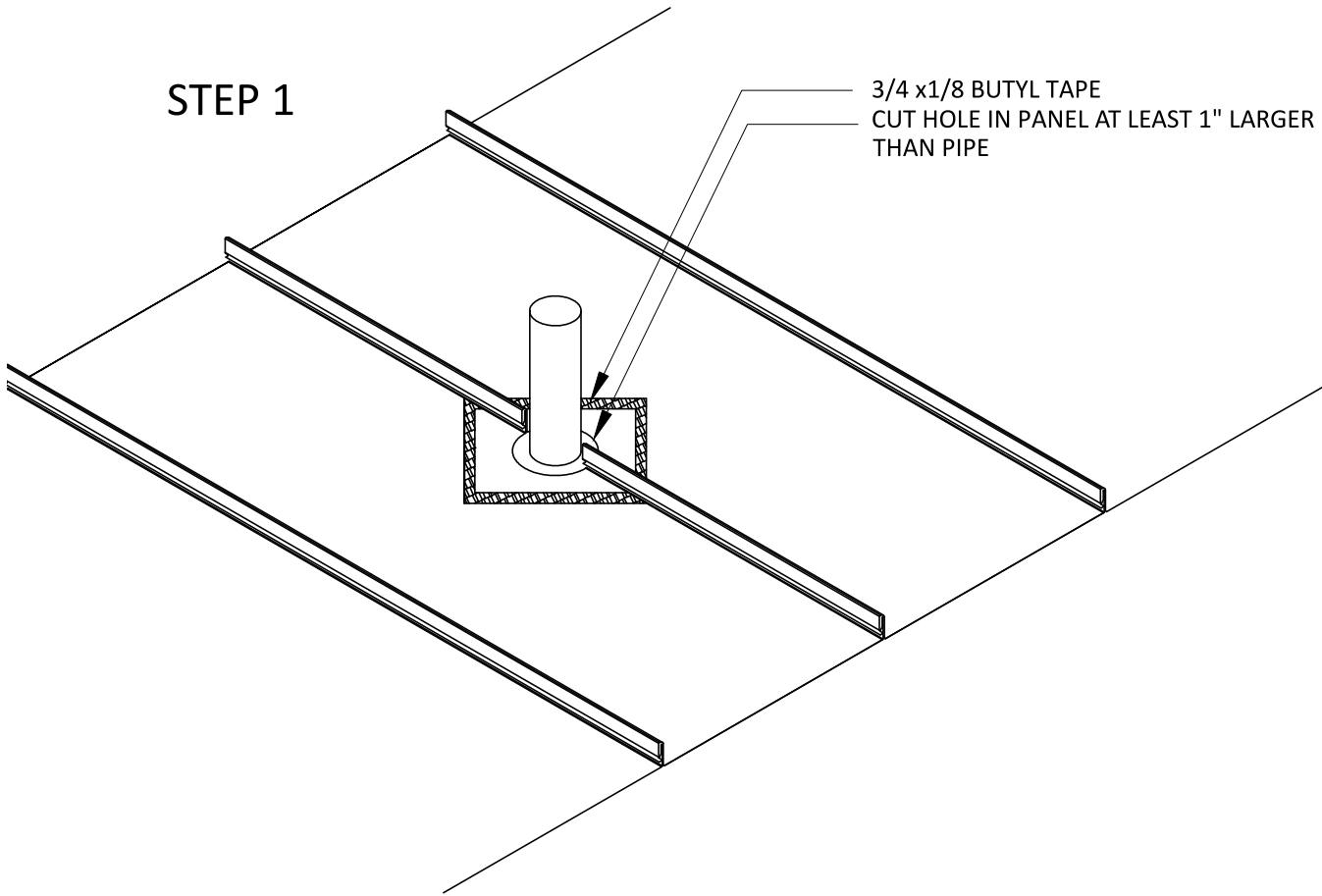

STEP 2

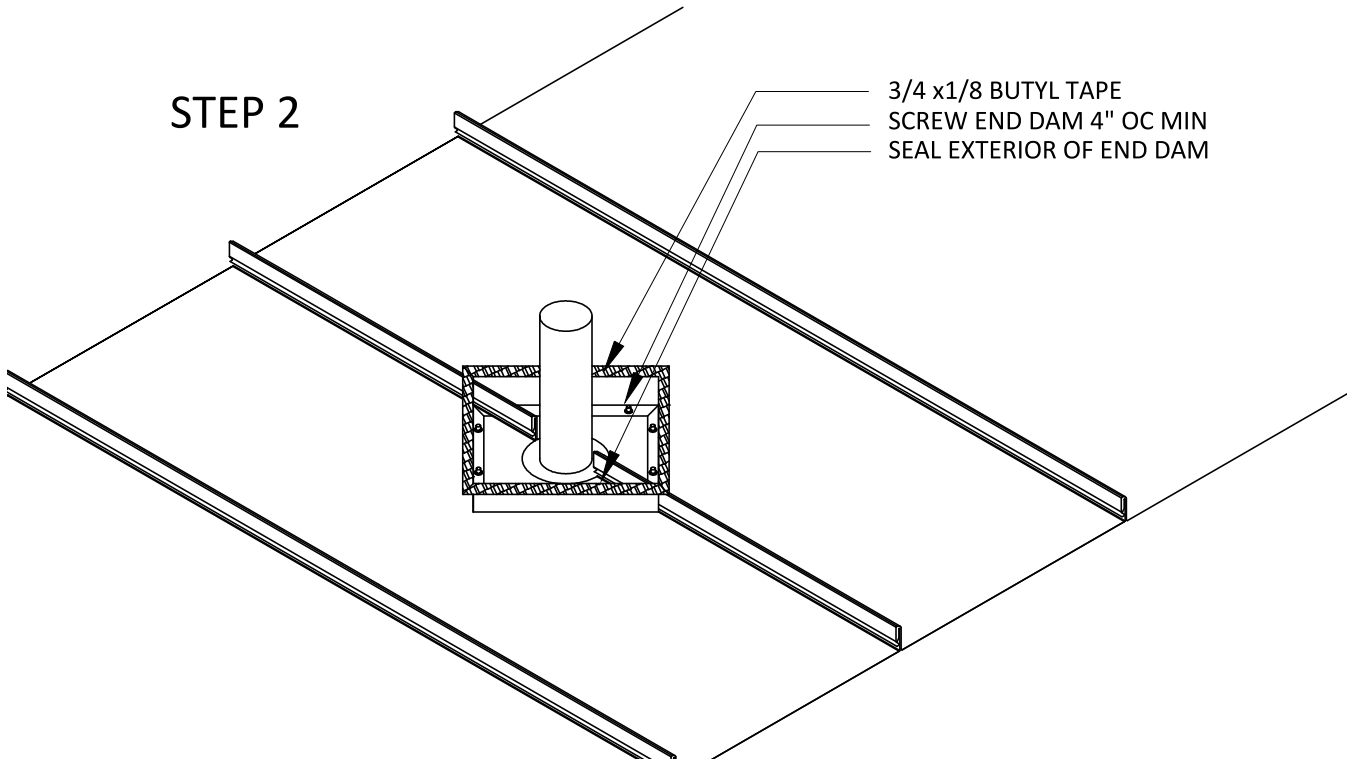



PIPE PENETRATION

STEP 3

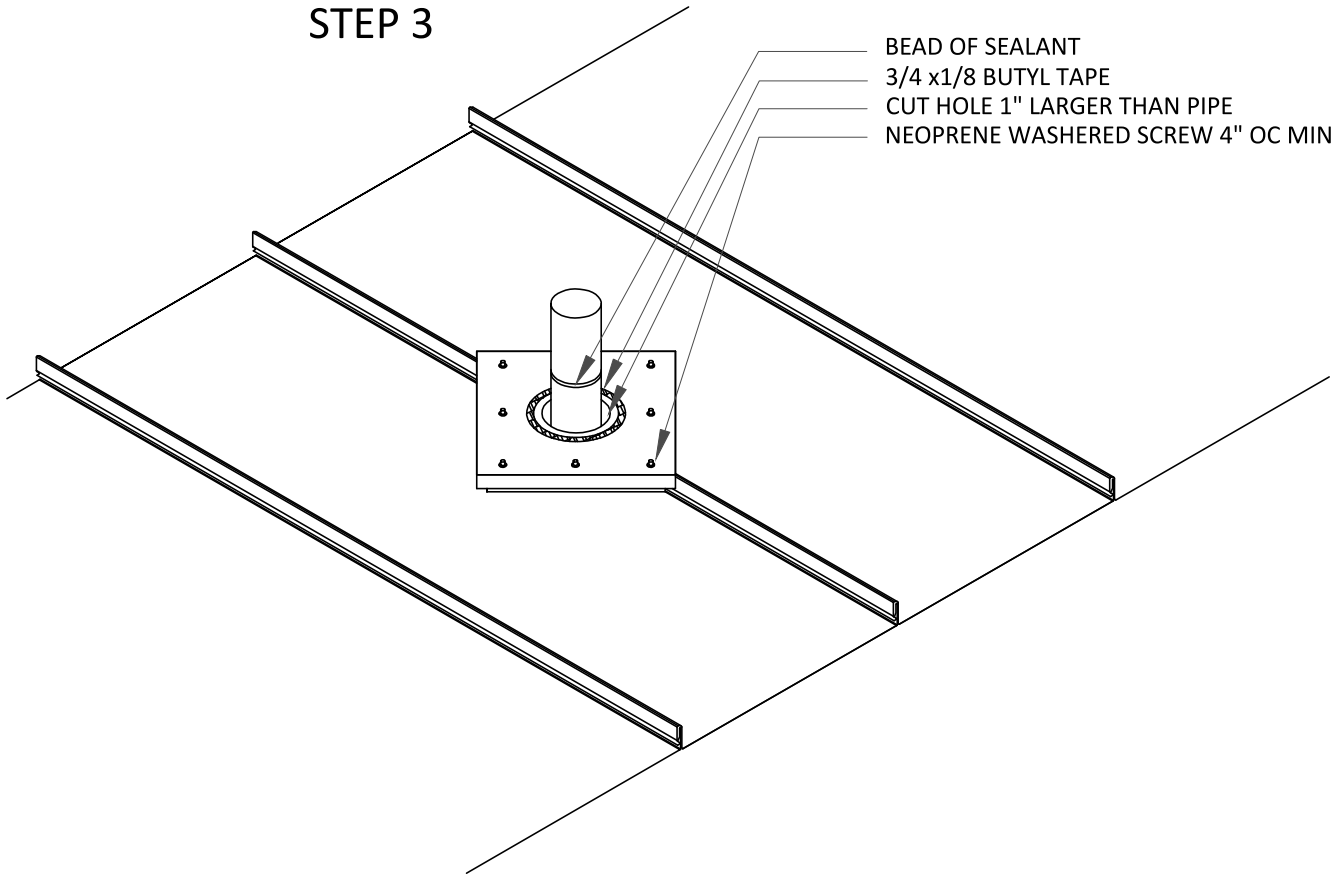

STEP 4

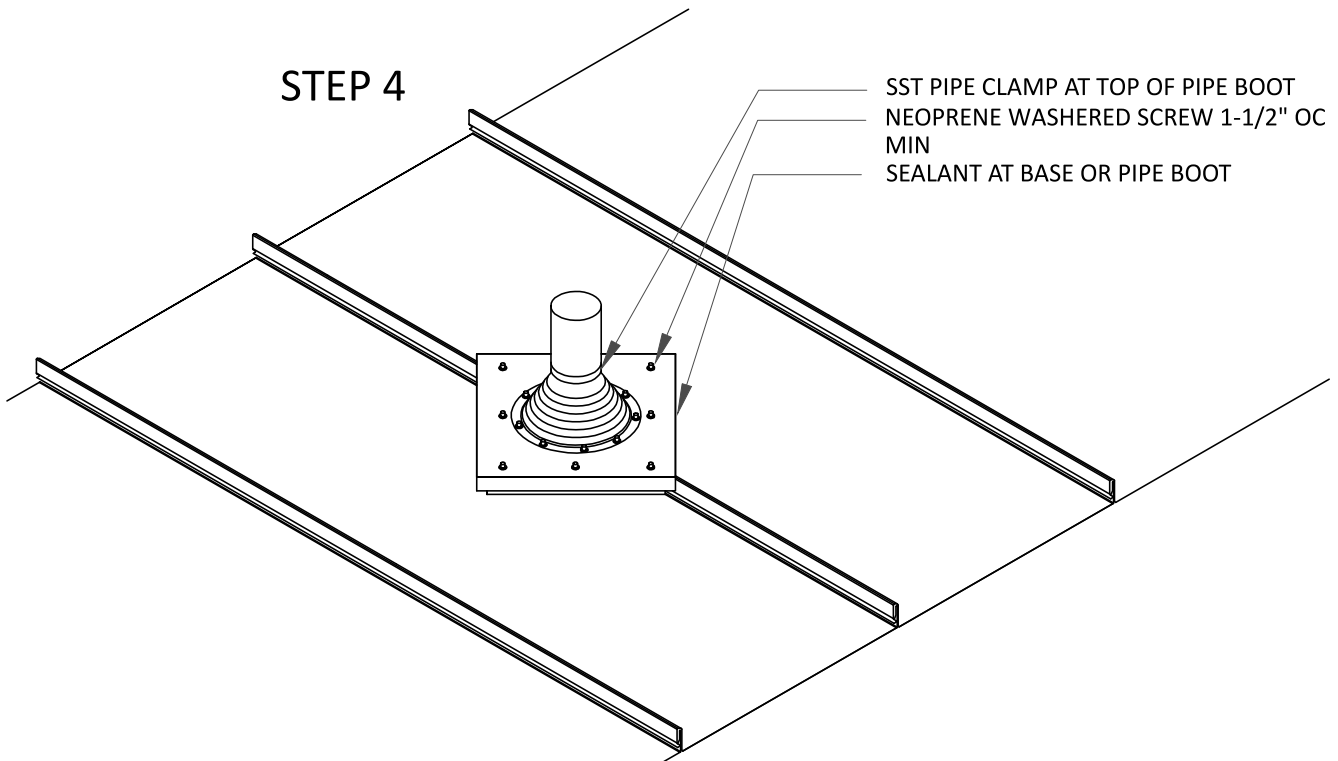



PIPE PENETRATION

STEP 1

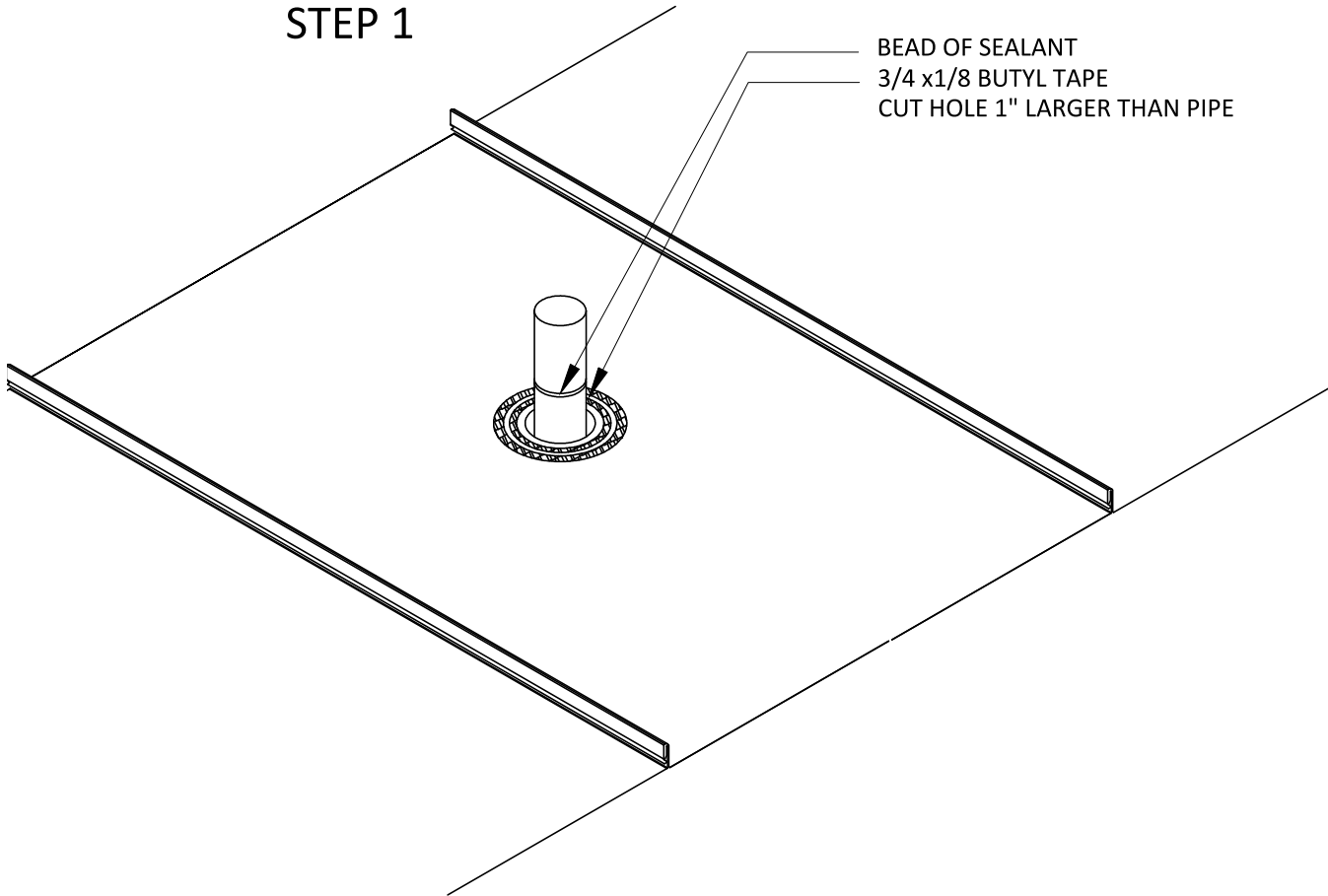

STEP 2

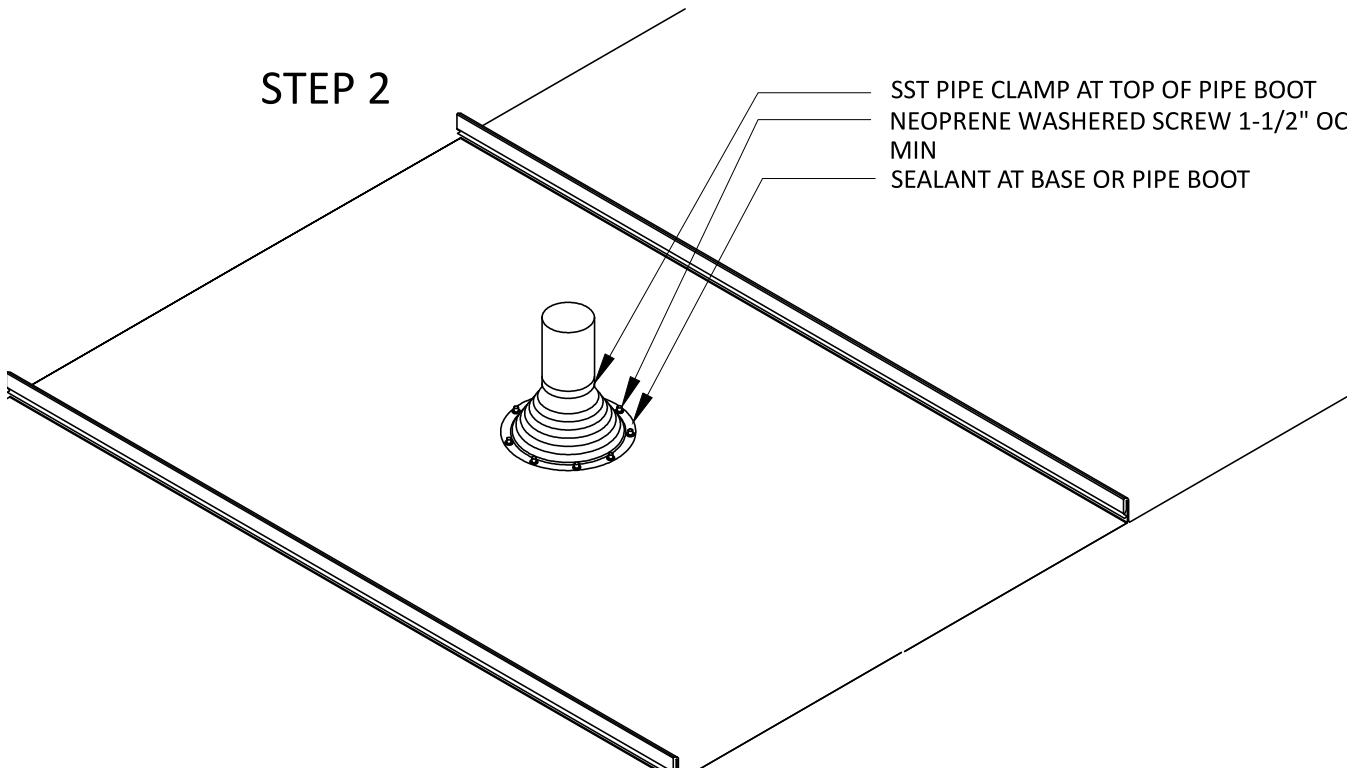



END DAM

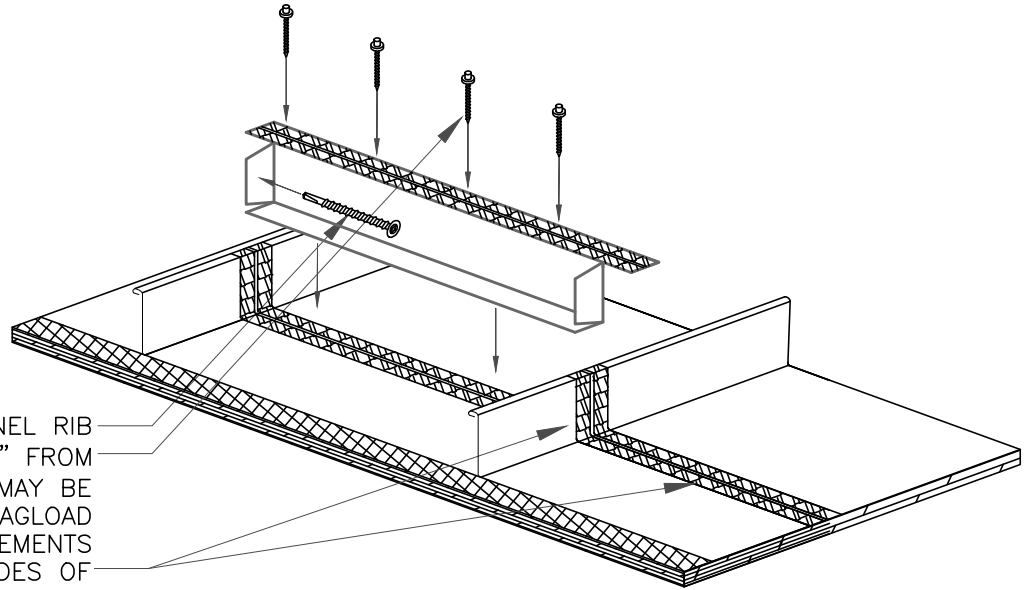

SCREW END DAM TO PANEL RIB
NEOPRENE WASHERED SCREW 1" FROM
RIB AND 4" OC. MORE MAY BE
REQUIRED DEPENDING ON DRAGLOAD
REQUIREMENTS
DOUBLE BEAD BUTYL TAPE, UP SIDES OF
RIB AND OVER THE TOP

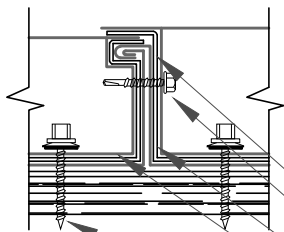

DOUBLE BEAD BUTYL TAPE
SCREW END DAM TO PANEL RIB
NON-SKINNING GUNNABLE BUTLE TO FILL ALL GAPS
END DAM SET IN DOUBLE BEAD BUTYL TAPE
NEOPRENE WASHERED DRAG LOAD 1" FROM SIDE OF RIB
AND 4" OC MIN, DRAG LOAD CALCS MAY REQUIRE MORE



MS Series flashing are 10' Long

EAVE STANDARD

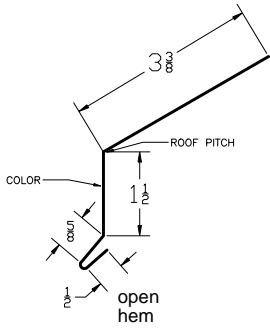

EAVE HOOK

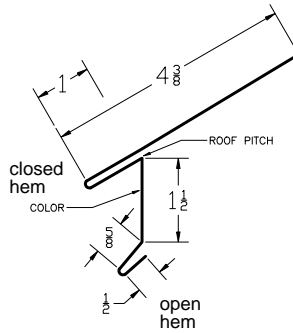

OFFSET CLEAT

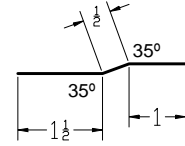

BOX GUTTER

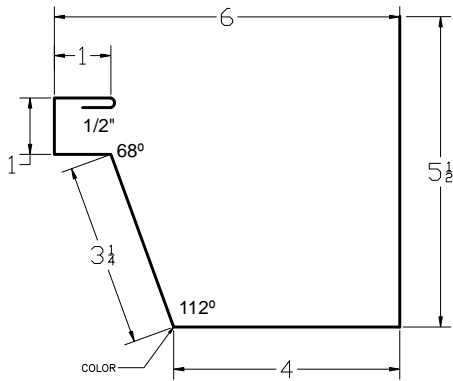

SUPPORT FLASHING

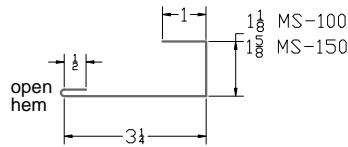

SIDE WALL

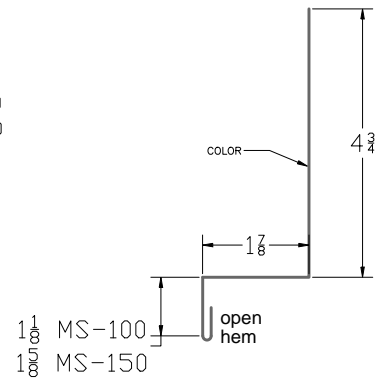

RIDGE END CAP

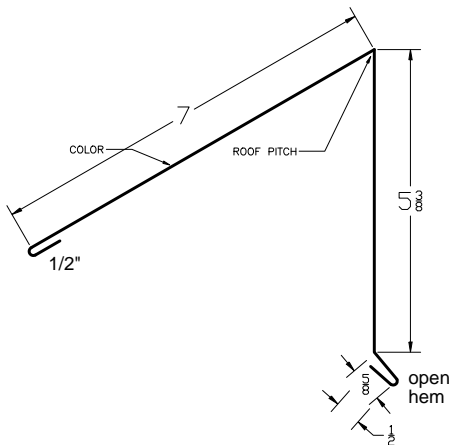

RIDGE END CAP CLEAT

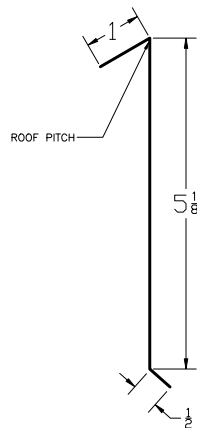

VENTED RIDGE END

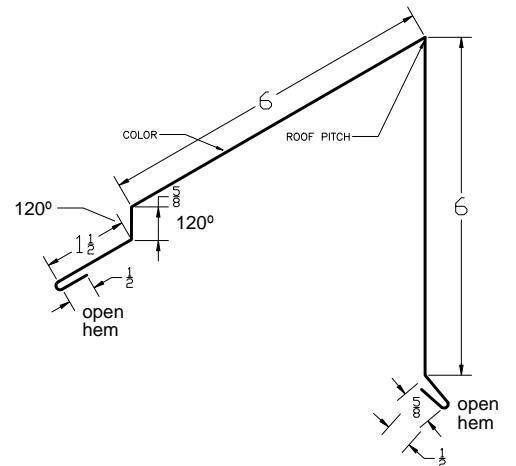



MS Series flashing are 10' Long

RIDGE

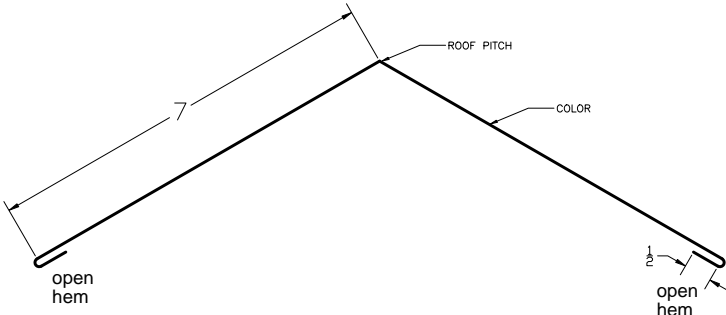

VENTED RIDGE

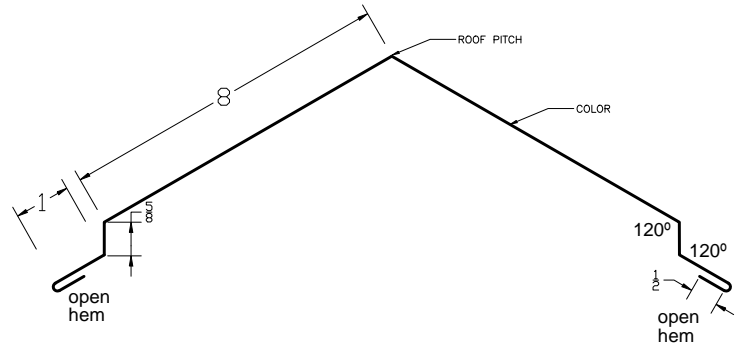

VENTED RIDGE END CAP CLEAT

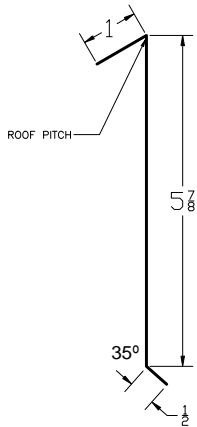

ENDWALL

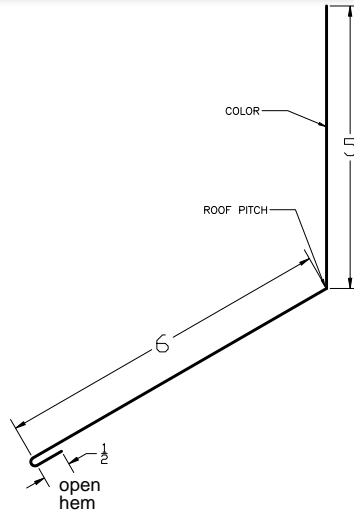

VENTED ENDWALL

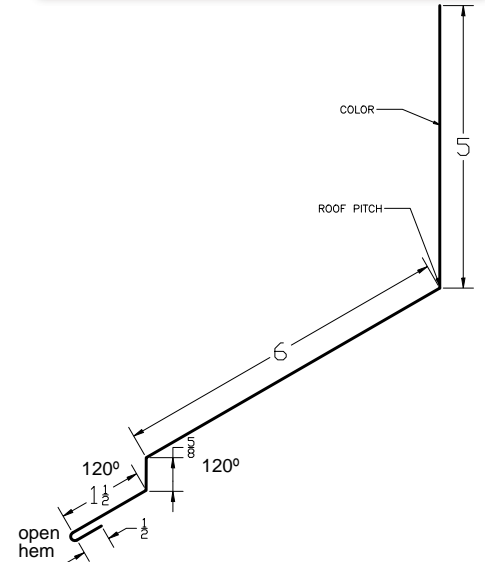

VALLEY FLASHING

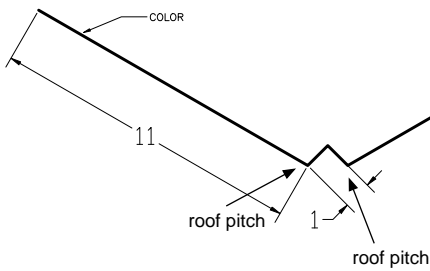

END DAM

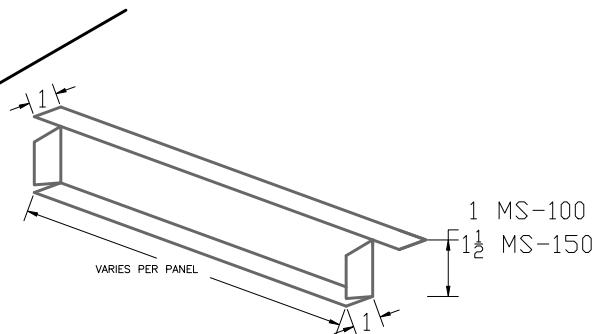

ZEE CLOSURE

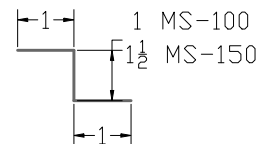



MS-Series flashing are 10' Long

STANDARD GABLE

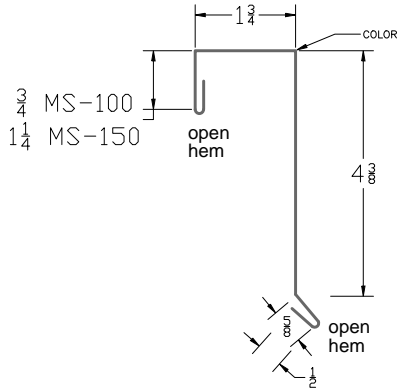

GABLE CLEAT

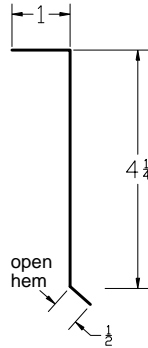

PERF

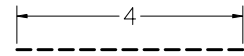

GABLE ALTERNATE L

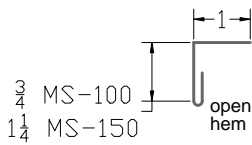

GABLE ALTERNATE

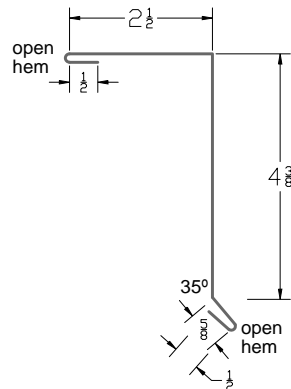

BACK PAN

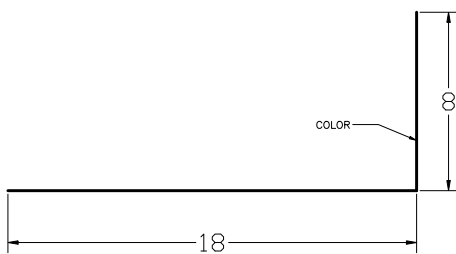

CURB HEAD

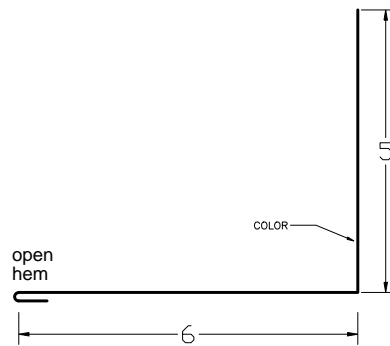

CURB SIDE WALL

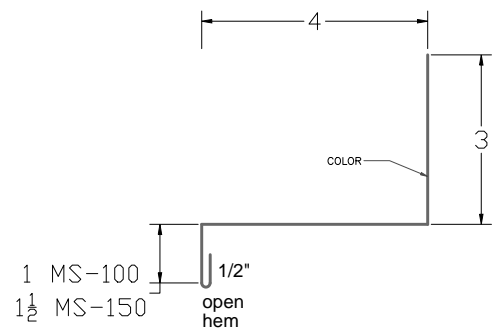



Customer Name: _____ Job Name: _____

Drawing #: _____ Pitch: _____ # of Pieces: _____
 Description: _____
 Hems: Open Closed Slightly Open

Drawing #: _____ Pitch: _____ # of Pieces: _____
 Description: _____
 Hems: Open Closed Slightly Open

Drawing #: _____ Pitch: _____ # of Pieces: _____
 Description: _____
 Hems: Open Closed Slightly Open

Drawing #: _____ Pitch: _____ # of Pieces: _____
 Description: _____
 Hems: Open Closed Slightly Open

Please provide a drawing for each flashing with precise measurements and angles
Fax to: 425-485-2710

WOODINVILLE BRANCH
5927 234th St. SE
Woodinville, WA 98072

Office: 425-485-3003
Toll Free: 1-800-574-1388
Fax: 425-485-2710



CHAMPION METAL
a Taylor Metal Company